

COACH'S GUIDE FOR NETSETGO



Set Session Plans

8 – 10 YEARS

What is NetSetGO?

NetSetGO is Netball Australia's only junior entry netball program. It provides children aged from 5 to 10 years with the best possible learning and playing experience to develop a positive introduction to netball, ensuring enjoyment and continued participation.

NetSetGO incorporates skill activities, minor games, music, dance and modified matches in a fun and safe environment. The weekly program is coordinated by accredited coaches to ensure a quality experience for all participants.

The program consists of two tiers, Net and Set, and to ensure a consistent approach to the delivery of NetSetGO, Netball Australia has developed resourcing to support coaches in this area.



NetSetGO

Net Tier (5 – 7 years)

Focus: Developing fundamental motor skills through netball activities.

Delivery: The NetSetGO Net session plans have been developed to provide a sequential 10-session program for delivery within a NetSetGO Centre program. Players will be encouraged to develop fundamental motor skills in a netball environment by being involved in individual, small and large group games. Activities should allow for maximum participation and repetition, with the key outcomes for each having a direct link to a netball-specific skill.

Set Tier (8 – 10 years)

Focus: Applying skill to modified games.

Delivery: The NetSetGO Set session plans have been developed to provide a sequential 10-session program for delivery within a NetSetGO Centre program. Players will be involved in activities that have a specific netball skill outcome, and activities will allow players to make more decisions and execute skills in small-sided netball games while learning the rules of the sport. Players will hone their skill execution and decision-making in this program.

The Set tier can be delivered as a skills-only program or a combination of skill program and modified NetSetGO competition.

Session Plans

Activity Cards

As part of each session plan, a number of activity cards have been designed to ensure a consistent approach to delivery, development, use of language and coaching for coaches delivering at a NetSetGO Centre.

What's on a card?

Objectives: Clearly defined netball-specific learning outcomes relevant to the activity. Coaches should base their delivery, support, discussion and questioning around these.

Start out/Get into it/Finish up: The format of each session is broken up into a warm up (Start out: 10–15 minutes), skill development and minor game (Get into it: 30–35 minutes) and modified game/cool down (Finish up: 5–10 minutes).

Equipment/area: What equipment and area is required to play the activity.

Group management: What group numbers are required.

Description: Provides simple instructions on how to deliver the activity.

Coaching tips: Provides key technical and tactical coaching points to guide coaching as participants are engaged in the activity. More detailed coaching points can be found in the appendix of this resource.

Change it: Ideas on how to change the activity to reflect the developmental stage of the group and individual. Down = Easier; Up = Harder.

Questions: Examples of individual and group questions that can be asked to develop awareness around technical or tactical aspects of the game.

Minor Games

The minor game variations are included at each level of the program in the 'Get into it' sections. These invasion games allow players to practise and develop skills in a game-like environment without actually playing a match. Minor games may be modified by changing the rules, increasing or decreasing the activity space or setting time restrictions. The coach can decide whether they use the minor game identified in the session plan, or use their discretion to choose an appropriate variation based on the development of their players.

Set Session Plans

SESSION

1

Knee Tag

Objective

To practise change of direction and dodge techniques.

Equipment/Area

Netball court or suitable playing area.

Group Management

Pairs.

Description

In pairs, partners face each other.

Partners try to tag each other's knees while avoiding being tagged.

Players cannot turn and run away from their partner.



⚠ Safety

Define the area appropriate for numbers.

🎯 Coaching Tip

Eyes looking forward.

Push off the ground with the ball of the foot.

Back leg extends to push off and give more momentum.

Legs and feet move in a straight line.

Arms bent at right angles at the elbows.

Arms and legs move in opposition.

Body leans forward.

↻ Change It

Down: Increase distance from partner.

Up: Decrease distance from partner.

Toe Tag

Objective

To practise change of direction.

Equipment/Area

Netball court or suitable playing area.

Group Management

Pairs.

Description

In pairs, partners face each other with hands behind their back.

Partners try to step on each other's toes while avoiding the other players standing on theirs.

⚠ Safety

Define the area appropriate for numbers, ensuring there is sufficient space between each group.

👁 Coaching Tip

Eyes looking forward.

Push off the ground with the ball of the foot.

Back leg extends to push off and give more momentum.

Legs and feet move in a straight line.

Arms bent at right angles at the elbows.

Arms and legs move in opposition.

Body leans forward.

🔄 Change It

Down: Allow players to have arms out for balance.

Up: Introduce a competition between pairs.

❓ Question

What did you do to avoid being tagged?

Hopping Fight

Objective

To develop balance technique in a dynamic activity.

Equipment/Area

Netball court or suitable playing area.

Lines.

Group Management

Pairs.

Description

Players facing each other across a line, holding each other's upper arms firmly.

On 'go', players try to hop their partners over the line.

Repeat using the other leg.



! Safety

Define the area appropriate for numbers, ensuring there is sufficient space between each group.

Reinforce the importance of holding on to their partner.

🎯 Coaching Tips

Eyes forward.

Bend at the knee, hips and ankles.

↻ Change It

Down: Hop forward and back over a line with no partner.

Up: Play Hoppo Bumpo (cross arms and hop and bump partner off balance).

? Question

What did you do to keep your balance and not get pushed over the line?

Leap Frog

Objective

To practise jumping and landing techniques.

Equipment/Area

Netball court or suitable playing area.

Group Management

Groups of 3–4.

Description

Divide group into teams.

Participants leapfrog the width of the court.

⚠ Safety

Define the area appropriate for numbers, ensuring there is sufficient space between each group.

🎯 Coaching Tips

Leap:

- Eyes looking forward
- Take off from one foot and land on opposite foot
- Arms and legs move in opposition.

Two-foot land:

- Land softly with two feet shoulder-width apart
- Keep body upright
- Bend at ankles, knees and hips
- Knees should stay in line with the feet over the toes.

One-foot land:

- Land softly and bring the other foot down quickly
- Keep body upright
- Bend at ankles, knees and hips
- Knee should stay in line with the foot over the toe.

↔ Change It

Down: Leap over only one person.

Up: Introduce a competition.

❓ Question

Which technique helped you jump over the person in front of you?

🏃 Stretch!

Select an appropriate activity from the Stretch Coaching resource.

Throw to Self Using a Bean Bag

Objective

To practise catching in a controlled environment.

Equipment/Area

Netball court or suitable playing area.

Bean bags.

Group Management

Individuals/pairs.

Description

Individuals:

- Throw to self, high in the air and catch in the palms
- Throw to self in the air and catch with favourite hand
- Throw to self in the air and catch with the other hand
- Throw to self and clap once before catching
- Throw to self and turn 180 degrees before catching.

Pairs:

- Each partner has a bean bag which they pass to each other
- Use one bean bag per pair, and the thrower can pass anywhere.

⚠ Safety

Define the area appropriate for numbers, ensuring there is sufficient space between each group.

🎯 Coaching Tips

Eyes on the bean bag.

Hands towards the bean bag.

Pull bean bag towards the body.

↻ Change It

Down: Just do individual activities.

Up: Combine a number of activities in sequence.

❓ Questions

Which activity was the easiest?

Which activity was the most difficult?

Why do you think this was?

Balance Using the Ball

Objective

To practise balance technique while holding a ball.

Equipment/Area

Netball court or suitable playing area.

Size 4 netballs (or equivalent).

Group Management

Pairs.

Description

One player stands inside the goal circle and holds the ball out in front, one step back from the goal circle line.

The other player is the worker and stands outside the goal circle and balances while taking the ball from the player inside.

The player inside the goal circle takes a step back each time.

The worker must retain balance and not go offside.



⚠ Safety

Ensure there is sufficient space between the groups and there is an awareness of safety considerations such as avoiding the area near the goalpost.

👁 Coaching Tips

Eyes looking forward.

Bend at knees as required.

Thumbs behind the ball when taking the ball.

Feet shoulder-width apart.

↻ Change It

Down: Use a softball or bean bag.

Up: Worker starts off the circle edge and runs up to take the ball.

❓ Question

What did you do to keep balance and not go offside?

Reaction Time / Toss-Up

Objectives

- To practise quick reaction time.
- To practise hand–eye coordination.

Equipment/Area

- Netball court or suitable playing area.
- Size 4 netballs (or equivalent).

Group Management

- Groups of 3–4.

Description

Individuals:

- On the whistle, players clap their own hands in front.

Pairs:

- On the whistle, players clap the hands of their partner.

In groups of three:

- A and B set up 0.9m apart for a toss-up. C acts as umpire and does the toss-up (if there is no whistle, just say go). If using four players, the winner of the toss-up passes to D.

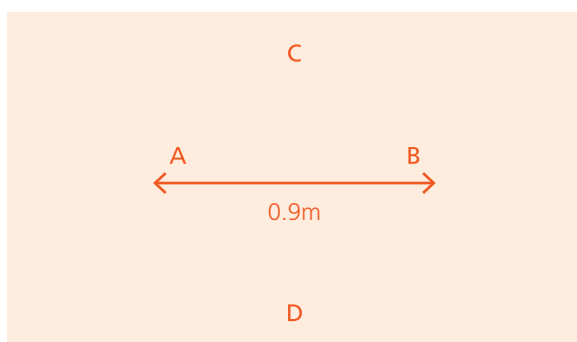

⚠ Safety

Define the area appropriate for numbers, ensuring there is sufficient space between each group.

👁 Coaching Tips

Players to watch the ball in the umpire's hands.
Step forward and snatch the ball with both hands.

↻ Change It

Up: Add in additional players to pass to after winning the toss-up.

❓ Question

What did you look for (cues) to help you know when the ball was going to be released?

Skittles

Objective

To practise passing and catching with decision-making under pressure.

Equipment/Area

Netball court or suitable playing area.

Size 4 netballs (or equivalent).

Bibs.

Skittles or markers.

Group Management

Two groups.

Description

Play Players form two even teams.

Four skittles are placed in each goal circle.

Start with a toss-up.

Players work the ball towards their goal circle.

From the edge of the goal circle players aim to throw the ball at one of the four skittles.

One point is scored for each skittle knocked over.

The other team restarts the game with the ball after each shot.

NetSetGO rules apply.

The first team to knock down all four skittles wins.



⚠ Safety

Define the area appropriate for numbers.

Reinforce the importance of looking out for other players also moving within the area.

🎯 Coaching Tips

Pass:

- Eyes on target
- Step towards target (this should be opposite foot to throwing arm for shoulder pass)
- Transfer weight forward
- Hip to shoulder rotation during throw
- Throwing arm follows through to target.

Catch:

- Eyes on the ball
- Hands towards the ball
- Fingers forward and spread and thumbs behind the ball ('W' formation)
- Pull ball towards the body.

🔄 Change It

Down: Set up numbers netball (minor games activity) so less players are on the court at once; Increase the size of the skittles and/or put them closer together.

Up: Decrease the size of the skittles and/or put them further apart.

❓ Question

What has your team done well if you manage to knock down all four skittles?

NetSetGO Game

Objective

To develop understanding of a modified netball game.

Equipment/Area

Netball court or suitable playing area.

Modified goalposts.

Size 4 netball (or equivalent).

Bibs.

Group Management

Two even teams.

Description

Play a modified game.

Introduce the goal shooter (GS) position.

- What is their role?
- What area do they play in?

! Safety

Define the area appropriate for numbers.

Reinforce the importance of looking out for other players also moving within the area.

🎯 Coaching Tips

Reinforce footwork rule.

Encourage correct passing and catching technique.

Reinforce use of attacking moves to create space.

Encourage players to shadow/stay close when defending opponent.

👉 Coach Tip

Treat players as individuals.

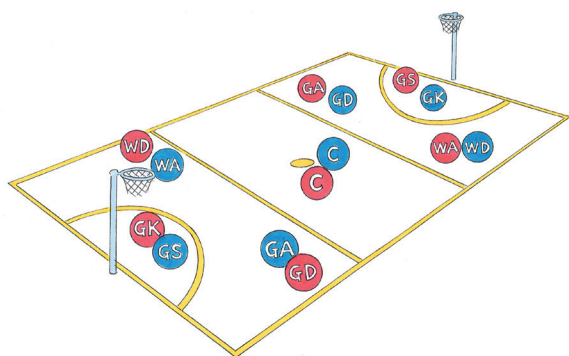

Concluding Activity

Objective

To reinforce skills and positions learnt.

Description

Summarise skills covered.

Stretch!

Select an appropriate activity from the Stretch Coaching resource.

Set Session Plans

SESSION

2

Rob the Nest

Objectives

To develop running technique at different speeds and in varying directions.

To work as a team to achieve the task.

Equipment/Area

Netball court or suitable playing area.

Bean bags.

Size 4 netballs (or equivalent).

Hoops.

Group Management

Four groups.

Description

Place netballs in the middle of the centre circle.

Divide players into four teams and line up at the corners of the centre third.

Each team sends a runner to rob an egg (netball) from a nest. They return the egg to their nest and the next person in line then goes to rob an egg.

Players collect eggs from the middle or from other nests. Teams cannot stop others stealing their eggs.

Play for two minutes, reset and then play again.

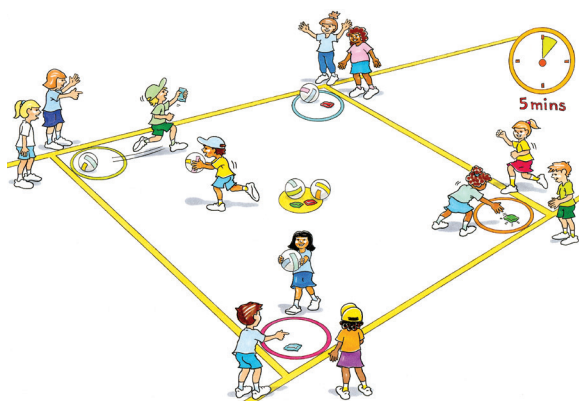

! Safety

Define the area appropriate for numbers.

Reinforce the importance of looking out for other players also moving within the area.

🎯 Coaching Tips

Eyes looking forward.

Push off the ground with the front part of the foot.

Extend back leg.

Knees bent at right angles when moving forward.

Legs and feet move in a straight line.

Arms bent at right angles at the elbows.

Arms and legs move in opposition.

Contact ground with front part of foot.

Body leans forward.

↻ Change It

Down: Use beanbags; Decrease distance of running; Increase the number of netballs/bean bags.

Up: Increase distance of running.
Winner is the first team with three eggs.

🏃 Stretch!

Select an appropriate activity from the Stretch Coaching resource.

Passing vs Running Relay

Objective

To practise passing and running techniques.

Equipment/Area

Netball court or suitable playing area.

Size 4 netball (or equivalent).

Markers.

Group Management

Two teams.

Description

Team X passes the ball around the circle anywhere, counting the number of passes out loud.

Team O runs around the circle (one by one).

When Team O has all run around once, swap roles.

Compare the number of passes.

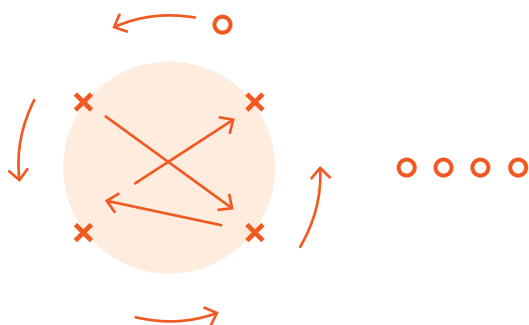

⚠ Safety

Define the area appropriate for numbers.

🎯 Coaching Tips

Pass:

- Head up, eyes on the ball
- Transfer weight forward
- Fingers forward and spread and thumbs behind the ball ('W' formation)
- Ball comes out evenly from both hands.

Run:

- Eyes looking forward
- Push off the ground with the front part of the foot
- Extend back leg
- Knees bent at right angles when moving forward
- Legs and feet move in a straight line
- Arms bent at right angles at the elbows
- Arms and legs move in opposition
- Contact ground with front part of foot
- Body leans forward.

🔄 Change It

Down: Use bean bags instead of a ball.

Up: Make the circle bigger.

❓ Questions

What helped you pass the ball quickly?

What slowed you down?

Teach Passing in Pairs

Objectives

To develop passing techniques – lob/bounce.

To practise passing techniques – shoulder/chest.

Equipment/Area

Netball court or suitable playing area.

Size 4 netball (or equivalent).

Group Management

Pairs.

Description

Pairs approximately 3–4 metres apart should do 20 passes each:

- Shoulder
- Chest
- Lob
- Bounce.

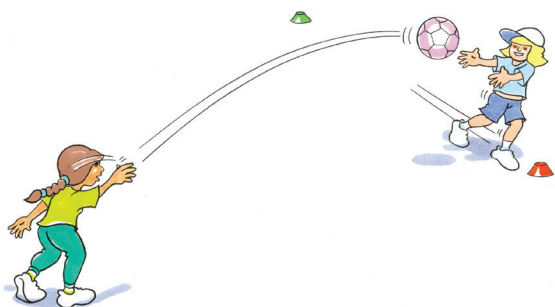

! Safety

Define the area appropriate for numbers.

🕒 Coaching Tips

Lob:

- Start movement from the shoulder
- Short back movement
- One-handed high release
- Follow through in direction of pass with wrist/fingers.

🕒 Coaching Tips (cont.)

Bounce:

- Step forward and bend/lunge on opposite leg
- Push ball forward and downward
- Release ball between the hip and knee
- The path of the ball is lower, under the outstretched hands of the defender
- The ball should touch the ground approximately two thirds of the distance to the receiver and reach the intended player about knee height.

Shoulder:

- Eyes on target
- Step towards target (this should be opposite foot to throwing arm for shoulder pass)
- Transfer weight forward
- Hip to shoulder rotation during throw
- Throwing arm follows through to target.

Chest:

- Head up, eyes on the ball
- Transfer weight forward
- Fingers forward and spread and thumbs behind the ball ('W' formation)
- Ball comes out evenly from both hands.

Catch:

- Eyes on the ball
- Hands towards the ball
- Fingers forward and spread and thumbs behind the ball ('W' formation)
- Pull ball towards the body.

🔄 Change It

Down: Use a soft ball.

Up: Introduce a competition.

? Question

When would you use these types of passes in a game?

Crossball

Objective

To practise a variety of passing techniques.

Equipment/Area

Netball court or suitable playing area.

Size 4 netball (or equivalent).

Group Management

Groups of 5–6.

Description

Players line up opposite each other.

X1 starts with the ball and passes to player opposite.

Practise execution of shoulder, lob, bounce and chest passes in cross-ball formation.

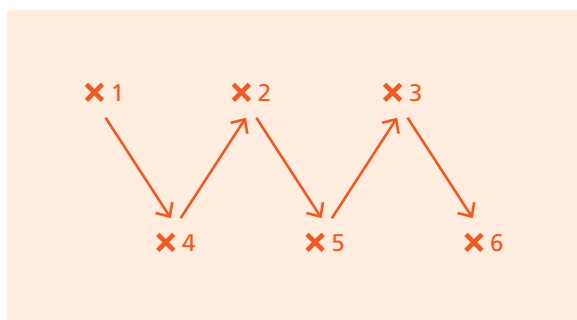

⚠ Safety

Define the area appropriate for numbers.

🎯 Coaching Tips

Lob:

- Start movement from the shoulder
- Short back movement
- One-handed high release
- Follow through in direction of pass with wrist/fingers.

🎯 Coaching Tips (cont.)

Bounce:

- Step forward and bend/lunge on opposite leg
- Push ball forward and downward
- Release ball between the hip and knee
- The path of the ball is lower, under the outstretched hands of the defender
- The ball should touch the ground approximately two thirds of the distance to the receiver and reach the intended player about knee height.

Shoulder:

- Eyes on target
- Step towards target (this should be opposite foot to throwing arm for shoulder pass)
- Transfer weight forward
- Hip to shoulder rotation during throw
- Throwing arm follows through to target.

Chest:

- Head up, eyes on the ball
- Transfer weight forward
- Fingers forward and spread and thumbs behind the ball ('W' formation)
- Ball comes out evenly from both hands.

Catch:

- Eyes on the ball
- Hands towards the ball
- Fingers forward and spread and thumbs behind the ball ('W' formation)
- Pull ball towards the body.

🔄 Change It

Down: Use a soft ball or bean bag.

Up: Introduce a competition.

❓ Question

Which pass did you find easiest/most difficult?

Bench Ball

Objective

To practise netball skills in a match-like game.

Equipment/Area

Netball court or suitable playing area.

Size 4 netballs (or equivalent).

Group Management

Groups of 6–10.

Description

Two players from each team are on the court, with the rest of the team on the baseline.

Start with a toss-up.

Players work the ball to their baseline while the other team defends.

Once they get the ball across the line, an extra player comes on for each team.

The ball goes back to the centre and the other team starts.

Play as NetSetGO rules for intercept, out of court, step, etc.

Encourage a variety of passes.

! Safety

Define the area appropriate for numbers.

Reinforce the importance of looking out for other players also moving within the area.

🎯 Coaching Tips

Reinforce footwork rule.

Encourage correct passing and catching technique.

Reinforce use of attacking moves to create space.

Encourage players to shadow/stay close when defending opponent.

↔ Change It

Down: Reduce space from a full court to a third or two thirds of the court.

Up: Require a number of passes/types of passes before a team can cross the baseline.

? Questions

How does this relate to a netball game?

What different passes did you use?

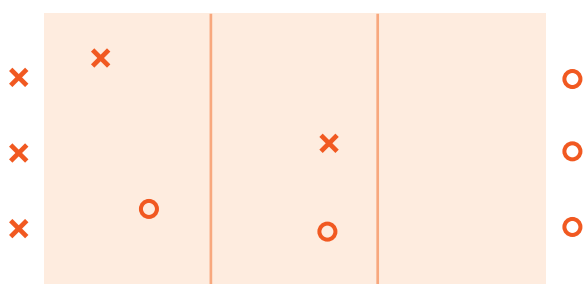

NetSetGO Game

Objective

To practise netball skills in a modified NetSetGO match.

Equipment/Area

Netball court or suitable playing area.

Modified goalposts.

Size 4 netball (or equivalent).

Bibs.

Group Management

Two even teams.

Description

Play a modified game.

Introduce the goal keeper (GK) position.

- What is their role?
- What area do they play in?

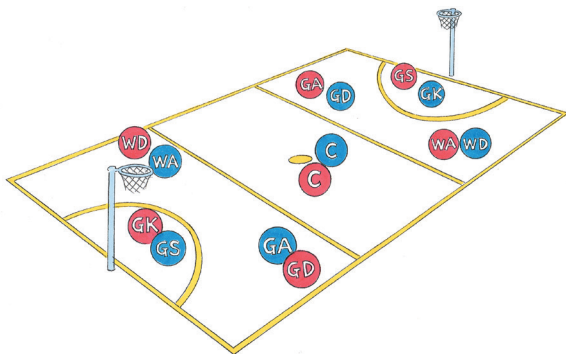

! Safety

Define the area appropriate for numbers.

Reinforce the importance of looking out for other players also moving within the area.

🎯 Coaching Tips

Reinforce footwork rule.

Encourage correct passing and catching technique.

Reinforce use of attacking moves to create space.

Encourage players to shadow/stay close when defending opponent.

📌 Coach Tip

Reinforce coaching points.

Concluding Activity

Objective

To develop understanding of a netball game.

Description

Summarise skills covered.

Stretch!

Select an appropriate activity from the Stretch Coaching resource.

Net Session Plans

SESSION

3

Pairs Chasey

Objective

To practise running technique and change of direction to evade tagger.

Equipment/Area

Netball court or suitable playing area.

Group Management

Pairs.

Description

Players stand in pairs with arms linked.

One pair is separated, with one player chasing their partner.

The player being chased can link arms with another pair. The player on the opposite end must unlink arms as they are now the player being chased.

If the player being chased is tagged, the roles are reversed.



! Safety

Define the area appropriate for numbers.

Reinforce the importance of looking out for other players also moving within the area.

🎯 Coaching Tips

Eyes looking forward.

Push off the ground with the ball of the foot.

Back leg extends to push off and give more momentum.

Legs and feet move in a straight line.

Arms bent at right angles at the elbows.

Arms and legs move in opposition.

Body leans forward.

↻ Change It

Down: Reduce the number of pairs;
Decrease the size of the area.

Up: Increase the size of the area.

🏃 Stretch!

Select an appropriate activity from the Stretch Coaching resource.

Body Wrap

Objective

To develop hand–eye coordination and ball control.

Equipment/Area

Netball court or suitable playing area.

Size 4 netballs (or equivalent).

Group Management

Pairs.

Description

Wrap the ball around the waist, knees or head.

Work for period of time or set number of wraps.

Repeat in the opposite direction.

⚠ Safety

Define the area appropriate for numbers, ensuring there is sufficient space between each group.

🎯 Coaching Tips

Eyes on the ball.

Hands towards the ball.

Fingers forward and spread and thumbs behind the ball ('W' formation).

Pull ball towards the body.

↻ Change It

Down: Use a softer ball; Catch a partner's ball so the catch is in front of the body.

Up: Bounce the ball repeatedly from front to back then front.

Figure 8

Objective

To develop hand–eye coordination and ball control.

Equipment/Area

Netball court or suitable playing area.

Size 4 netballs (or equivalent).

Group Management

Pairs.

Description

Wrap the ball around each leg alternately in a figure 8 pattern.

Work for a period of time or set number of wraps.

The pattern can be repeated alternating a figure 8 pattern around a single leg lift.

⚠ Safety

Define the area appropriate for numbers, ensuring there is sufficient space between each group.

🎯 Coaching Tips

Eyes on the ball.

Hands towards the ball.

Fingers forward and spread and thumbs behind the ball ('W' formation).

Pull ball towards the body.

↻ Change It

Down: Use a softer ball; Catch a partner's ball so the catch is in front of the body.

Up: Bounce the ball repeatedly from front to back then front.

Bounce Ball Between Legs

Objective

To develop hand–eye coordination and ball control.

Equipment/Area

Netball court or suitable playing area.

Size 4 netballs (or equivalent).

Group Management

Pairs.

Description

Bounce the ball between the legs from front to back (catch behind).

Repeat, bouncing the ball from back to front.

⚠ Safety

Define the area appropriate for numbers, ensuring there is sufficient space between each group.

🎯 Coaching Tips

Eyes on the ball.

Hands towards the ball.

Fingers forward and spread and thumbs behind the ball ('W' formation).

Pull ball towards the body.

↻ Change It

Down: Use a softer ball; Catch a partner's ball so the catch is in front of the body.

Up: Bounce the ball repeatedly from front to back then front.

Pepper Pot

Objective

To practise passing and catching techniques in a dynamic activity.

Equipment/Area

Netball court or suitable playing area.

Size 4 netballs (or equivalent).

Group Management

Groups of 5–6.

Description

Each group stands in a semi-circle, two balls per group.

Player 1 can pass to anyone in the semi-circle, and at the same time the player with the ball in the semi-circle passes to 1.

All have a go at being 1.

Use both chest and shoulder passes.

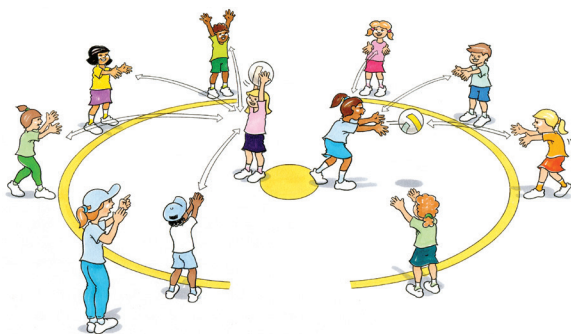

⚠ Safety

Define the area appropriate for numbers.

Reinforce the importance of making sure the player is ready to receive the ball.

🎯 Coaching Tips

Feet shoulder-width apart.

Shoulders back and down.

Knees slightly flexed.

Knees over toes.

Head up with eyes looking in direction of play.

Arms relaxed by side of body.

Centre of gravity is low and over base of support.

↻ Change It

Down: Use a soft ball or bean bag;
Make the semi-circle smaller.

Up: Add in an additional ball; Introduce
a competition; Increase the distance.

❓ Question

What did you do to make sure your pass was accurate?

Bunny

Objectives

To practise passing and catching techniques.

To develop intercept technique.

Equipment/Area

Netball court or suitable playing area.

Size 4 netballs (or equivalent).

Group Management

Groups of 5–6.

Description

The thrower (T) stands out in front. The bunny (B) stands approximately four metres away, and the workers (W) line up behind.

The thrower tosses the ball up and catches it, then passes to the bunny. A worker runs around in front of the bunny to catch out in front, balances and passes to the thrower.

Workers move around to both left and right sides.

Rotate the thrower and bunny positions.



! Safety

Define the area appropriate for numbers.

Reinforce the importance of making sure the player is ready to receive the ball.

🎯 Coaching Tips

Reiterate strong take-off technique.

Reiterate passing and catching technique.

Eyes forward, watching the ball.

Run through and take the ball, land on the outside foot.

↻ Change It

Down: Use lob passes.

Up: Use a range of passes.

? Question

What helped you take off quickly to intercept the pass?

Half-Court Numbers Netball

Objective

To develop passing and catching with defensive pressure.

Equipment/Area

Netball court or suitable playing area.

Size 4 netballs (or equivalent).

Modified goalposts.

Bibs.

Group Management

Groups of 10–12.

Description

Two teams, consecutively numbered, line up on the sideline.

The coach stands near the post with the ball and calls a number and passes the ball into the space (lob/roll/pass).

The player who gets the ball must pass it three times to their team on the sideline to get the ball into the circle and have a shot.

The beaten player defends and attempts to intercept.

If the intercept is successful, or after a shot is taken, the game is started again by returning the ball to the coach, who calls a new number.

A ball into the goal circle scores two points, with an additional point if a goal is scored.

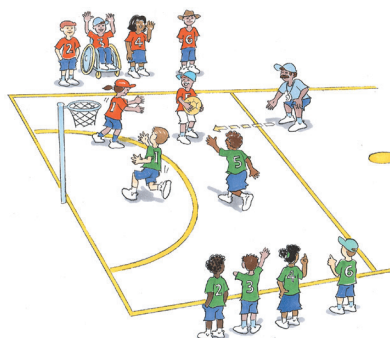

! Safety

Define the area appropriate for the numbers and selected activity.

🎯 Coaching Tips

Pass:

- Eyes on target
- Step towards target (this should be opposite foot to throwing arm for shoulder pass)
- Transfer weight forward
- Hip to shoulder rotation during throw
- Throwing arm follows through to target

Catch:

- Eyes on the ball
- Hands towards the ball
- Fingers forward and spread and thumbs behind the ball ('W' formation)
- Pull ball towards the body

↻ Change It

Down: Use a soft ball; Use two balls, one for each team; Reduce space.

Up: Set a number of passes that must be completed before a point is scored; All players must touch the ball to score.

? Question

How does this relate to a netball match?

What types of passes did you use?

NetSetGO Game

Objective

To practise netball skills in a modified NetSetGO match.

Equipment/Area

Netball court or suitable playing area.

Modified goalposts.

Size 4 netball (or equivalent).

Bibs.

Group Management

Two even teams.

Description

Play a modified game.

Introduce the goal attack (GA) position.

- What is their role?
- What area do they play in?

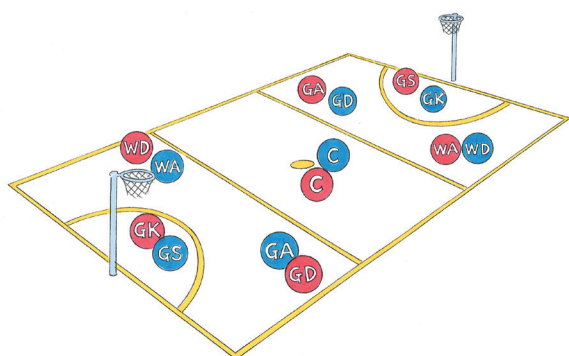

! Safety

Define the area appropriate for numbers.

Reinforce the importance of looking out for other players also moving within the area.

🎯 Coaching Tips

Reinforce footwork rule.

Encourage correct passing and catching technique.

Reinforce use of attacking moves to create space.

Encourage players to shadow opponent and attempt to intercept.

📌 Coach Tip

Keep it simple.

Concluding Activity

Objective

To reinforce skills and positions learnt.

Description

Summarise skills covered.

Stretch!

Select an appropriate activity from the Stretch Coaching resource.

Set Session Plans

SESSION

4

Netball Tag (Variation)

Objectives

To practise running and change of direction in a dynamic activity.

To practise passing and catching technique in a dynamic activity.

Equipment/Area

Netball court or suitable playing area.

Size 4 netballs (or equivalent).

Bibs.

Group Management

As a group.

Description

Two players, each wearing a bib (attackers), pass a ball between themselves, moving the ball to be able to tag another player (by pivoting, not throwing the ball).

All other players must move around the space to avoid being tagged.

Once a player is touched by a ball they put on a bib to help the attackers.

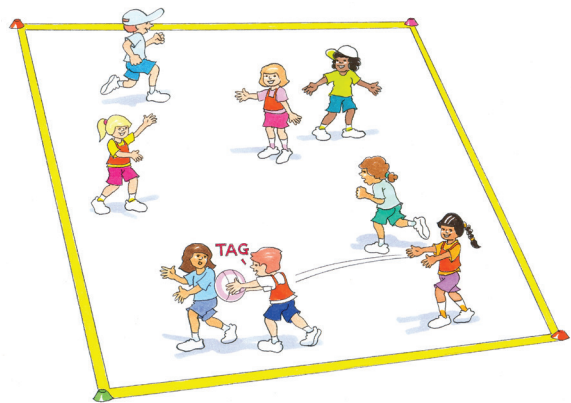

Netball Tag (Variation) (Cont.)

⚠ Safety

Define the area appropriate for numbers.

Ensure the ball does not leave the taggers' hands and is not thrown at players.

🎯 Coaching Tips

Run:

- Eyes looking forward
- Push off the ground with the ball of the foot
- Back leg extends to push off and give more momentum
- Legs and feet move in a straight line
- Arms bent at right angles at the elbows
- Arms and legs move in opposition
- Body leans forward
- Knee lifts

Change of direction:

- Eyes looking forward
- Shoulders in direction of movement
- Push off outside foot
- Body lower on change of direction

Pass:

- Eyes on target
- Step towards target (this should be opposite foot to throwing arm for shoulder pass)
- Transfer weight forward
- Hip to shoulder rotation during throw
- Throwing arm follows through to target

Catch:

- Eyes on the ball
- Hands towards the ball
- Fingers forward and spread and thumbs behind the ball ('W' formation)
- Pull ball towards the body

↻ Change It

Down: Increase the number of tagging players to make it easier for the taggers; Make the playing area smaller.

Up: Make the playing area larger; The tagging group aims to make as many tags as possible in a defined time.

❓ Questions

Where are the spaces to move within the playing area?

Why is it important to find a free space?

How does this relate to a netball game?

🏃 Stretch!

Select an appropriate activity from the Stretch Coaching resource.

Hoop Pivot with Runs

Objective

To practise pivoting technique.

Equipment/Area

Netball court or suitable playing area.

Size 4 netballs (or equivalent).

Hoops.

Group Management

Groups of 4–5.

Description

Place hoops randomly in the centre third of the court.

Players line up on sideline, thrower stands in the first hoop.

Player 1 runs to the vacant hoop nearest to the thrower to receive a pass, lands and pivots. Player 2 then runs to the next vacant hoop and receives a pass from player 1.

Continue down the line, following this sequence until all players have received a pass.

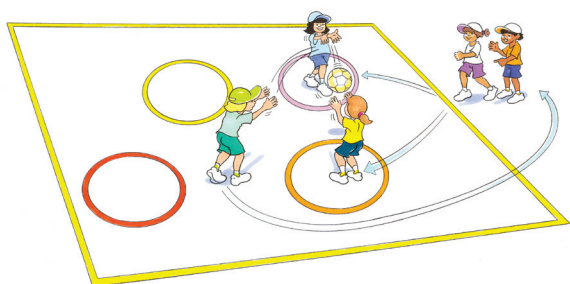

! Safety

Define the area appropriate for the numbers.

Ensure there is awareness of safety considerations such as sliding on hoops on slippery surfaces.

🎯 Coaching Tips

Bring weight over grounded foot.

Bend knees slightly.

Turn on ball of the pivot foot, pushing off with the other foot.

Non-grounded foot is lifted and regrounded to maintain balance throughout the movement.

Players must be able to turn quickly after receiving a pass and face the play down court.

Keep ball close to body and positioned ready to throw.

↻ Change It

Down: Use a soft ball or bean bag.

Up: Introduce a competition.

? Question

Which direction should you pivot before passing?

Hoop Pivot

Objective

To develop pivoting skills in a dynamic activity.

Equipment/Area

Netball court or suitable playing area.

Size 4 netballs (or equivalent).

Hoops.

Group Management

Groups of three.

Description

Player 1 and 2 line up behind each other, facing the thrower with a hoop between them.

Player 1 runs and receives a pass in the hoop from the thrower, then pivots 180 degrees and passes to player 2.

Players complete 10 passes and then swap (change sides).

The ball is passed out in front of player 1 so that they can land on the outside foot.

Players may use a two-foot landing at the start and then pivot outside.



! Safety

Define the area appropriate for the numbers.

Ensure there is awareness of the safety considerations such as sliding on hoops on slippery surfaces.

🎯 Coaching Tips

Bring weight over grounded foot.

Bend knees slightly.

Turn on ball of the pivot foot, pushing off with the other foot.

Non-grounded foot is lifted and regrounded to maintain balance throughout the movement.

Players must be able to turn quickly after receiving a pass and face the play down court.

Keep ball close to body and positioned ready to throw.

↻ Change It

Down: Player starts in the hoop.

Up: Vary direction of lead into the hoop.

? Question

What did you do to keep your pivot foot grounded?

Sideline Skittle Ball

Objective

To practise passing, catching and pivoting in a match-like game.

Equipment/Area

Netball court or suitable playing area.

Size 4 netballs (or equivalent).

Bibs.

Skittles or markers.

Group Management

Two even teams.

Description

Form two even teams with bibs.

Place one skittle in each goal circle.

Start with a toss-up in the centre circle.

Five players from each team are on court, with the remaining players along the sideline.

Players work the ball towards their goal circle, using members of their team on and off the court.

From the edge of the goal circle players aim to throw the ball at the skittle.

After an attempt at the skittle, the opposing team takes a pass just inside the goal circle to restart.

Count how many times the skittle is knocked down.

NetSetGO rules apply.

Rotate players on and off court.

! Safety

Define the area appropriate for numbers.

Reinforce the importance of looking out for other players also moving within the area.

🎯 Coaching Tips

Reinforce passing and catching technique.

Focus on correct pivoting technique.

↻ Change It

Down: Set up numbers netball (minor games activity) so less players are on the court at once; Increase the number of skittles and/or put them closer together.

Up: Set a number of passes that must be completed before a point is scored; All players must touch the ball to score.

? Question

What helped your team knock down the skittle?

NetSetGO Game

Objective

To practise netball skills in a modified NetSetGO match.

Equipment/Area

Netball court or suitable playing area.

Modified goalposts.

Size 4 netball (or equivalent).

Bibs.

Group Management

Two even teams.

Description

Play a modified game.

Introduce the goal defence (GD) position.

- What is their role?
- What area do they play in?

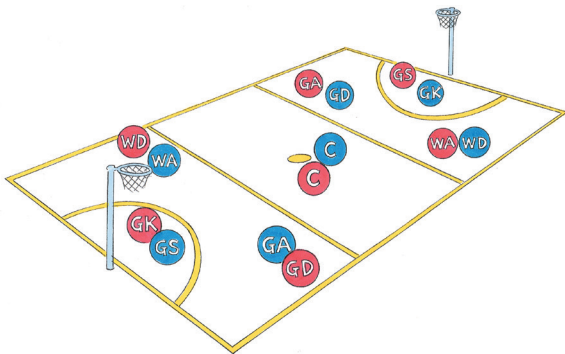

! Safety

Define the area appropriate for numbers.

Reinforce the importance of looking out for other players also moving within the area.

🎯 Coaching Tips

Reinforce footwork rule.

Encourage correct passing and catching technique.

Reinforce use of attacking moves to create space.

Encourage players to shadow opponent and attempt to intercept.

👉 Coach Tip

Enjoy your coaching.

Concluding Activity

Objective

To reinforce skills and positions learnt.

Description

Summarise skills covered.

Stretch!

Select an appropriate activity from the Stretch Coaching resource.

Net Session Plans

SESSION

5

START OUT (10–15 MIN)

Line Tag

Objective

To practise running and change of direction in a dynamic activity.

Equipment/Area

Netball court or suitable playing area.

Lines.

Group Management

Pairs.

Description

In pairs, a player runs along any line on the court and a partner chases.

When a player is tagged, swap roles. Work for three minutes.

⚠ Safety

Define the area appropriate for numbers, ensuring there is sufficient space between each group.

Reinforce the importance of looking out for other players also moving within the area.

🎯 Coaching Tips

Eyes looking forward.

Push off the ground with the ball of the foot.

Back leg extends to push off and give more momentum.

Legs and feet move in a straight line.

Arms bent at right angles at the elbows.

Arms and legs move in opposition.

Body leans forward.

↻ Change It

Down: Decrease/reduce space.

Up: Increase space.

🏃 Stretch!

Select an appropriate activity from the Stretch Coaching resource.

Throw to Self using a Ball

Objective

To develop hand–eye coordination and ball control.

Equipment/Area

Netball court or suitable playing area.

Size 4 netballs (or equivalent).

Group Management

Individuals.

Description

Complete some/each of the following:

- Bounce ball with two hands and catch
- Throw to self in the air and catch
- Throw to self and clap once before catching
- Repeat, extending the number of claps
- Throw to self and turn 180 degrees before catching
- Throw to self and touch the ground before catching.

! Safety

Define the area appropriate for numbers, ensuring there is sufficient space between each group.

🕒 Coaching Tips

Eyes on the ball.

Hands towards the ball.

Fingers forward and spread and thumbs behind the ball ('W' formation).

Pull ball towards the body.

↻ Change It

Down: Use a soft ball or bean bag.

Up: Add/increase the number of claps.

? Questions

Which was the easiest to catch?

What was the hardest to catch?

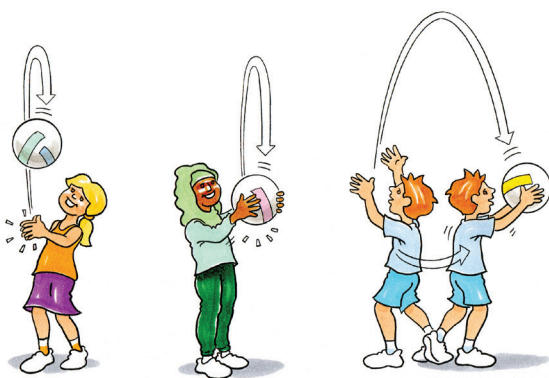

Throw and Catch

Objective

To develop hand–eye coordination and ball control.

Equipment/Area

Netball court or suitable playing area.

Size 4 netballs (or equivalent).

Group Management

Individuals.

Description

Throw the ball in the air and:

- clap once before catching
- turn around 180 degrees before catching
- touch the ground and catch.

Repeat each activity five times.

! Safety

Define the area appropriate for numbers, ensuring there is sufficient space between each group.

🎯 Coaching Tips

Eyes on the ball.

Hands towards the ball.

Fingers forward and spread and thumbs behind the ball ('W' formation).

Pull ball towards the body.

↻ Change It

Down: Use a soft ball or bean bag.

Up: Add/increase the number of claps.

? Questions

Which was the easiest to catch?

What was the hardest to catch?

Shooting Action

Objective

To develop goal-shooting technique in a dynamic activity.

Equipment/Area

Netball court or suitable playing area.

Size 4 netballs (or equivalent).

Wall.

Group Management

Individuals.

Description

Player throws ball in the air, jumps to catch, lands and pivots to the wall and goes through the shooting action.

! Safety

Define the area appropriate for numbers, ensuring there is sufficient space between each group.

🎯 Coaching Tips

Emphasise landing technique and correct pivot action.

Encourage players to have their feet, hips and elbows pointing towards the goalpost.

Players should avoid shooting with 'chicken wings' (elbows sticking out to the side) as this develops poor technique for shooting.

Ensure maximum participation by keeping group numbers low. Use this time to deliver some discrete or small group coaching.

↔ Change It

Down: Use a soft ball.

Up: Introduce a passer.

? Questions

What are the important things to remember when practising goal shooting?

Shuffle Shot Relay

Objective

To practise goal-shooting technique in a dynamic activity.

Equipment/Area

Netball court or suitable playing area.

Size 4 netballs (or equivalent).

Modified goalposts.

Group Management

Groups of 4–5.

Description

Form a line of players starting at the transverse line.

The ball is passed along the line to the front, where a player pivots, balances and shoots.

The ball is retrieved and passed to the front person who passes it down the line.

The shooter returns to the back of the line, and the activity starts again.

There can be 2–4 lines.

The lines should have a maximum of 4–5 participants.

Players should use chest passes.

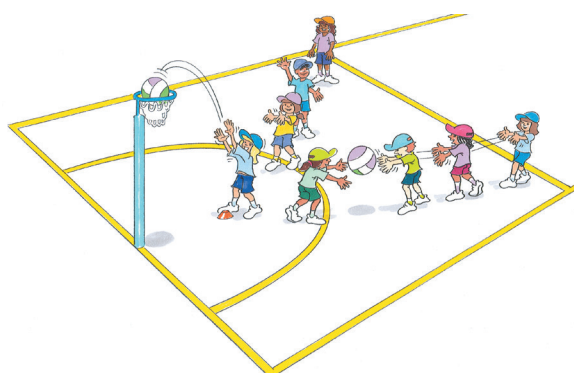

! Safety

Define the area appropriate for numbers.

Ensure there is sufficient space between groups and there is an awareness of safety considerations such as avoiding the area near the goalpost and rebounding balls.

🎯 Coaching Tips

Encourage players to have their feet, hips and elbows pointing towards the goalpost.

Players should avoid shooting with 'chicken wings' (elbows sticking out to the side) as this develops poor technique for shooting.

Ensure maximum participation by keeping group numbers low. Use this time to deliver some discrete or small group coaching.

↻ Change It

Down: Reduce group size.

Up: Repeat the passing sequence in a zig-zag pattern to reach the front player who has an attempt at goal; Develop a scoring system and time challenge; Develop a number of goal options (for example, basket, hoop, ring, modified ring, bin) and scoring options (for example, two points for a goal, one point if it hits the ring).

? Questions

What needs to happen so we safely pass the ball down the line?

When you had a successful shot at goal, where did you aim?

🛠️ Coach Tip

Give players the choice of the level of shooting challenge (that is, full height shots or modified goals).

Lead, Receive and Shoot

Objective

To practise goal-shooting technique in a dynamic activity.

Equipment/Area

Netball court or suitable playing area.

Size 4 netballs (or equivalent).

Modified goalposts.

Group Management

Groups of five.

Description

Players form two groups of five in the goal third.

The thrower on each side of the goalpost stands on the baseline.

The worker runs towards and into the circle to receive a pass, balance and shoot.

The ball is retrieved and the worker becomes the new thrower, with the old thrower going to the end of the line.

Ensure players work from both sides.

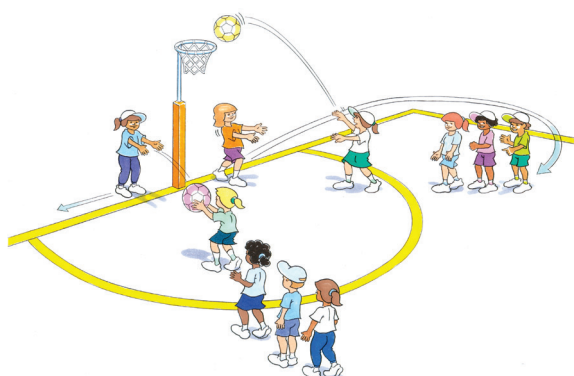

⚠ Safety

Define the area appropriate for numbers.

Ensure there is sufficient space between groups and there is an awareness of safety considerations such as avoiding the area near the goalpost and rebounding balls.

🎯 Coaching Tips

Emphasise landing technique and correct pivot action.

Encourage players to have their feet, hips and elbows pointing towards the goalpost.

Players should avoid shooting with 'chicken wings' (elbows sticking out to the side) as this develops poor technique for shooting.

Ensure maximum participation by keeping group numbers low. Use this time to deliver some discrete or small group coaching.

↻ Change It

Down: Worker starts just inside the circle to shorten lead.

Up: Worker takes two passes from thrower before shooting.

❓ Question

What helped you successfully shoot for goal after taking a pass?

NetSetGO Game

Objective

To practise netball skills in a modified NetSetGO match.

Equipment/Area

Netball court or suitable playing area.

Modified goalposts.

Size 4 netball (or equivalent).

Bibs.

Group Management

Two even teams.

Description

Play a modified game.

Introduce the centre (C) position.

- What is their role?
- What area do they play in?

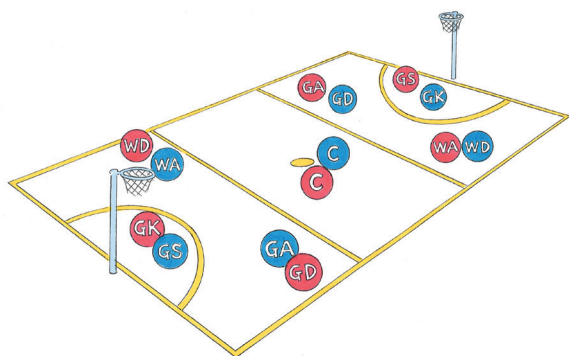

! Safety

Define the area appropriate for numbers.

Reinforce the importance of looking out for other players also moving within the area.

🎯 Coaching Tips

Reinforce footwork rule.

Encourage correct passing and catching technique.

Reinforce use of attacking moves to create space.

Encourage players to shadow opponent and attempt to intercept.

🧠 Coach Tip

Quality rather than quantity.

Concluding Activity

Objective

To reinforce skills and positions learnt.

Description

Summarise skills covered.

Stretch!

Select an appropriate activity from the Stretch Coaching resource.

Set Session Plans

SESSION

6

START OUT (10–15 MIN)

Rats and Rabbits

Objectives

To develop running and quick take off.

To reinforce the concept of 'ready position' in preparation for sprinting.

Equipment/Area

Netball court or suitable playing area.

Group Management

Two even teams.

Description

Players set up in two single-file lines next to a partner who is standing approximately one metre away.

One line of players is designated the 'rats' while the other is the 'rabbits'.

On the call of 'rats' or 'rabbits' the nominated group attempts to run to the safe area before their partner catches them.

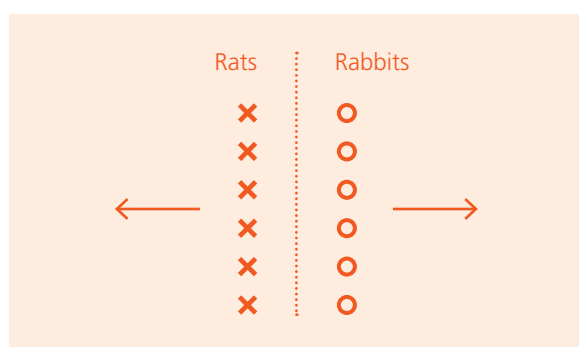

! Safety

Define the area appropriate for numbers.

Players need to run in straight lines to avoid collisions.

Ensure player safety by using lines with adequate run off.

🕒 Coaching Tips

Reinforce the concept of 'ready position' in preparation for sprinting.

Feet shoulder-width apart, body upright, knees slightly flexed and out over toes.

Push off on inside foot, stepping out in direction of lead.

Arms drive forward, elbows bent.

🔄 Change It

Players can keep a tally of scores, receiving one point if they catch their partner or one point if they reach the line before they are tagged by their partner.

Change the movement patterns (for example, side stepping, skipping, jumping).

Similar sounding names can be substituted for rats and rabbits, such as 'crusts and crumbs' or 'brats and brownies'.

Down: Increase the starting distance between the teams.

Up: The coach extends the 'r' sound so players are unsure of the call; After the first call (for example, 'Rabbits') and prior to them reaching the sideline, the coach calls 'Rats' who then have to turn and reach their sideline before being tagged.

? Questions

What starting position can you use to be ready to either catch your partner or avoid being caught by your partner?

When do you need to be ready for the whistle in a netball game?

Why is it important to have an explosive start?

🏃 Stretch!

Select an appropriate activity from the Stretch Coaching resource.

Dodge and Steal

Objective

To practise running technique and change of direction in a dynamic activity.

Equipment/Area

Netball court or suitable playing area.

Size 4 netballs (or equivalent).

Group Management

Groups of 5–6.

Description

Place a number of netballs behind each goal line.

Players are in two teams, one in each half of the court.

They try to steal an opponents' ball and return to their own half without being tagged.

⚠ Safety

Define the area appropriate for numbers.

Players need to run in straight lines to avoid collisions.

Ensure player safety by using lines with adequate run off.

Reinforce the importance of looking out for other players also moving within the area.

👁 Coaching Tips

Eyes looking forward.

Push off the ground with the ball of the foot.

Back leg extends to push off and give more momentum.

Legs and feet move in a straight line.

Arms bent at right angles at the elbows.

Arms and legs move in opposition.

Body leans forward.

↻ Change It

Down: Use the centre third instead of the full court.

Up: Place balls along the sideline as well.

❓ Question

Why is it important to have an explosive start?

Lead and Dodge

Objective

To develop dodge technique.

Equipment/Area

Netball court or suitable playing area.

Size 4 netballs (or equivalent).

Markers.

Group Management

Groups of four.

Description

Players line up on the sideline one behind the other, facing the thrower.

Place markers out in front at 45 degrees.

Player 1 leads (either left or right) to the marker, changes direction, then drives towards the thrower to take a pass.

Swap sides.

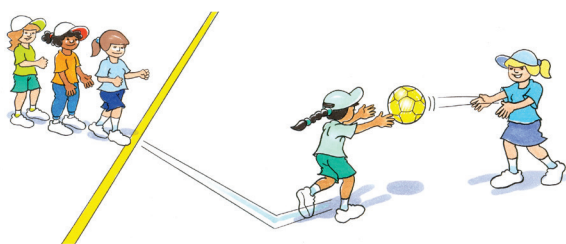

! Safety

Define the area appropriate for numbers.

🎯 Coaching Tips

Lead:

- Emphasis on strong first few steps with shoulders in direction of lead
- Strong arms to accelerate.
- Ensure the initial drive to the marker is at match speed (as this move needs to draw the defender before the attacker changes direction).

Dodge:

- Place outside foot strongly on ground and push off sharply in opposite direction, turning hips to face toward direction of travel.
- Ensure the set up of the area is large enough to ensure the movement is emphasized otherwise participants may do a head dodge.

↻ Change It

Down: Do the movement without the pass.

Up: Add a defender.

? Question

Why do you think it is important to have a strong lead and dodge?

Shake the Shadow

Objective

To develop dodge technique.

Equipment/Area

Netball court or suitable playing area.

Size 4 netballs (or equivalent).

Group Management

Pairs or groups of three.

Description

Pairs

- One player tries to evade their partner by dodging (2–3 steps each way) and 'shake the shadow'.
- The partner tries to stay within arm's length, so when the coach blows their whistle they can touch their partner.
- Players change roles and repeat.

Groups of three

- One player, the thrower (T), is out in front (2–3 steps).
- The attacking player (A) uses dodges to get away from the defending player (D).
- Players use only single dodges (make sure the player actually moves their feet rather than just doing a 'head dodge').
- The thrower passes the ball to the attacker.

! Safety

Define the area appropriate for numbers, ensuring there is sufficient space between the groups and there is an awareness of safety considerations such as avoiding the area near the goalposts.

🎯 Coaching Tips

Move a few steps away from the intended catching position (there should be a definite move).

Eyes on thrower.

Body upright, feet shoulder-width apart, slightly bent knees and hips.

Place outside foot strongly on ground and push off in the opposite direction, turning hips to face toward direction of travel.

Use arms to accelerate and extend to receive ball.

↻ Change It

Down: Stay in pairs.

Up: Add an additional pair of attacker/defender and set up a second pass.

? Question

What different attacking moves can you use to evade your opponent?

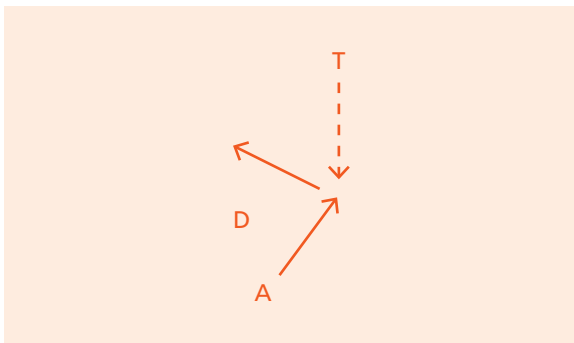

Line Drive

Objective

To practise change of direction and pivoting techniques.

Equipment/Area

Netball court or suitable playing area.

Size 4 netballs (or equivalent).

Group Management

As a group.

Description

Players line up on the sideline, one behind the other 3 metres apart.

Players face the thrower.

Player 1 drives out at 45 degrees, changes direction and drives forward at 45 degrees to receive a pass from the thrower. Player 1 then pivots on the outside foot and passes to the next player once they have completed their drive.

Continue down the line until everyone has had a turn.

Players work both sides.

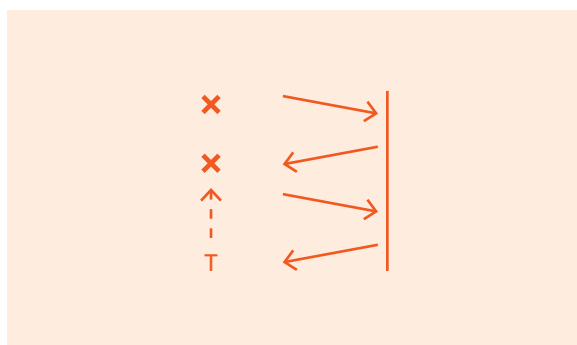

! Safety

Define the area appropriate for the numbers and selected activity.

🎯 Coaching Tips

Pass:

- Eyes on target.
- Step towards target (this should be opposite foot to throwing arm for shoulder pass)
- Transfer weight forward
- Hip to shoulder rotation during throw
- Throwing arm follows through to target.

Catch:

- Eyes on the ball
- Hands towards the ball
- Fingers forward and spread and thumbs behind the ball ('W' formation)
- Pull ball towards the body.

Lead:

- Run strongly to the ball, shoulders in direction of lead
- If leading right, land on the right foot
- If leading left, land on left foot.

Pivot:

- Pivot must always be on landed foot
- Turn on ball of the landed foot, pushing off with other foot
- Pivot in the direction of the landed foot.

Change of direction:

- Eyes looking forward
- Push off the ground with the ball of the foot
- Back leg extends to push off and give more momentum
- Legs and feet move in a straight line
- Arms bent at right angles at the elbows
- Arms and legs move in opposition
- Body leans forward.

 **Change It**

Down: Make it an activity for pairs rather than a group.

Up: Add a defender.

 **Question**

How could you use leads and change of direction to lose your opponent?

End Ball

Objective

To practise netball skills in a match-like activity.

Equipment/Area

Netball court or suitable playing area.

Size 4 netball (or equivalent).

Bibs.

Hoops/floor discs.

Group Management

Groups of 5–6.

Description

Players form two teams of approximately six players.

Each team selects an end person who stands in a hoop.

The game is started with a toss-up between two players.

Using NetSetGO rules, the team in possession passes the ball, attempting to score a goal by passing to the end person who must catch the ball on the full.

If successful, the player who threw the ball swaps places and becomes the goalie.

After a goal is scored the game is restarted with the opposite team taking a pass from behind the goal line.

No player other than the end person may step in a hoop or enter the goal area.



! Safety

Define the area appropriate for numbers.

Reinforce the importance of looking out for other players also moving within the area.

🎯 Coaching Tips

Pass:

- Eyes on target
- Step towards target (this should be opposite foot to throwing arm for shoulder pass)
- Transfer weight forward
- Hip to shoulder rotation during throw
- Throwing arm follows through to target.

Catch:

- Eyes on the ball
- Hands towards the ball
- Fingers forward and spread and thumbs behind the ball ('W' formation)
- Pull ball towards the body.

🔄 Change It

Down: Use a soft ball; Small group (for example, 3v3); Decrease the size of the area (for example, across a third).

Up: Increase the size of the area; Add a defender to the goal area (for example 1v1 in circle).

? Question

How does this activity relate to what happens in a netball match?

NetSetGO Game

Objective

To practise netball skills in a modified NetSetGO match.

Equipment/Area

Netball court or suitable playing area.

Modified goalposts.

Size 4 netball (or equivalent).

Bibs.

Group Management

Two even teams.

Description

Play a modified game.

Introduce the wing attack (WA) position.

- What is their role?
- What area do they play in?

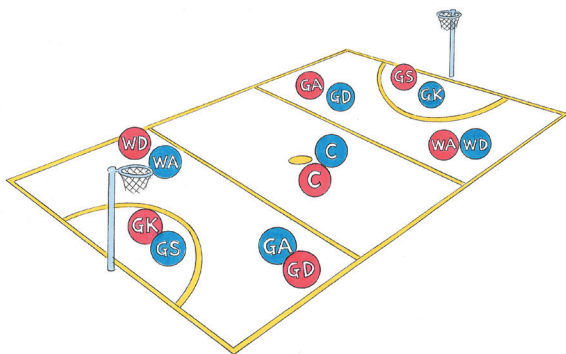

! Safety

Define the area appropriate for numbers.

Reinforce the importance of looking out for other players also moving within the area.

🎯 Coaching Tips

Reinforce footwork rule.

Encourage correct passing and catching technique.

Reinforce use of attacking moves to create space.

Encourage players to shadow opponent and attempt to intercept.

📌 Coach Tip

Question players to ensure understanding.

Concluding Activity

Objective

To reinforce skills and positions learnt.

Description

Summarise skills covered.

Stretch!

Select an appropriate activity from the Stretch Coaching resource.

Set Session Plans

SESSION

7

Octopus

Objective

To practise running and change of direction in a dynamic activity.

Equipment/Area

Netball court or suitable playing area.

Group Management

As a group.

Description

Players line up along the transverse line.

One player is in the middle, the octopus. This player calls 'octopus' and the rest of the group must run to the other side of the third without being tagged.

Tagged players sit down where they are tagged, keeping feet tucked in. These players help tag runners but cannot move from their spot.

The last player left untagged is the winner.

⚠ Safety

Define the area appropriate for numbers.

Reinforce the importance of looking out for other players also moving within the area.

🎯 Coaching Tips

Eyes looking forward.

Push off the ground with the ball of the foot.

Back leg extends to push off and give more momentum.

Legs and feet move in a straight line.

Arms bent at right angles at the elbows.

Arms and legs move in opposition.

Body leans forward.

↻ Change It

Down: Start with more participants in the middle being octopuses.

Up: Make the playing area larger.

🏃 Stretch!

Select an appropriate activity from the Stretch Coaching resource.

Triangle Tag

Objective

To practise change of direction using quick footwork movements.

Equipment/Area

Netball court or suitable playing area.

Bibs.

Group Management

Groups of four.

Description

Three players hold hands, with one of those players (X) wearing a bib.

The worker (W) attempts to tag X on their arms/legs.

The defenders (D) put themselves between the worker and X.

Each player should have a turn at being the worker.

Players protecting X should initiate movement (that is, X should not drag defenders around).

⚠ Safety

Define the area appropriate for numbers.

Reinforce the importance of looking out for other players also moving within the area.

🎯 Coaching Tips

Eyes looking forward.

Move feet using small steps – no lunging.

Feet shoulder-width apart.

Change direction by pushing off on outside foot.

🔄 Change It

Down: Decrease the size of the triangle.

Up: Increase the size of the triangle; Introduce a tagging time frame; Introduce a competition.

❓ Question

What did you do to tag player X?

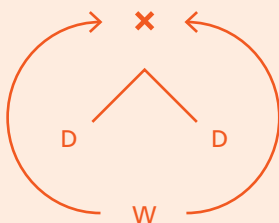

1.2m (4 feet) Stance

Objective

To practise quick footwork to recover to defending distance.

Equipment/Area

Netball court or suitable playing area.

Size 4 netballs (or equivalent).

Group Management

Individuals or groups of three.

Description

Individuals:

- Players start on the line, and then move with quick small steps back to 1.2m and put their hands up.

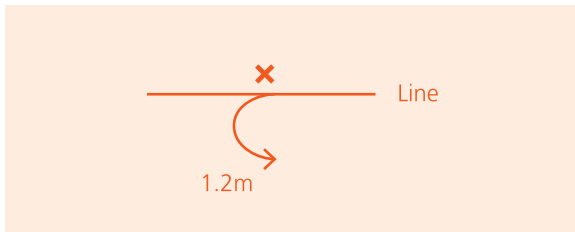

In groups of three

- Attacker (A) throws the ball up, catches it and pivots.
- Defender (D) must get back to 1.2m and put their arms up.
- Attacker (A) passes to receiver (R).

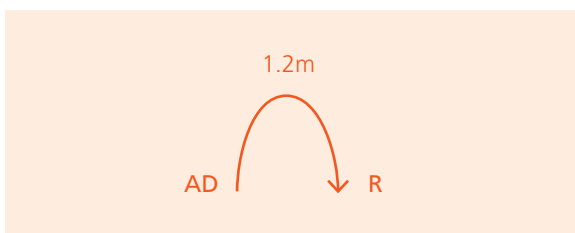

! Safety

Define the area appropriate for numbers, ensuring there is sufficient space between each group.

🎯 Coaching Tips

Eyes forward.

Bend at knees as required.

Use small steps to move backward to 1.2m keeping arms by sides.

Extend arms to defend ball.

↻ Change It

Down: Just continue with individual activity.

Up: Vary arms position when defending.

? Question

What helped you get back to defend quickly?

Hands Over Intercept Drill

Objective

To develop intercepting skill.

Equipment/Area

Netball court or suitable playing area.

Size 4 netballs (or equivalent).

Group Management

Groups of 7–8.

Description

Two defenders (D) are in the middle.

Throwers (T) pass to each other.

One defends positions at 1.2m (4 ft) and the other defender attempts to intercept.

Throwers can't pass to a person directly beside them.

Defenders recover after attempting an intercept to defend at 1.2m (4ft).

After score six points (one for tip, two for intercept), rotate roles.

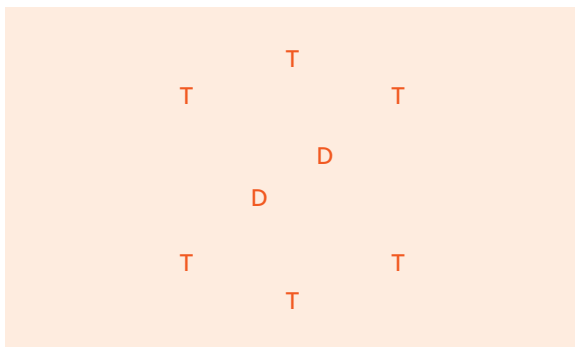

⚠ Safety

Define the area appropriate for numbers, ensuring there is sufficient space between each group.

🎯 Coaching Tips

Arms over pass:

- Eyes forward
- Bend at knees as required
- Use small steps to move backward to 1.2m, keeping arms by sides
- Extend arms to defend ball.

Intercept:

- Watch thrower to see where they are going to throw the ball (look for cues)
- Run at an angle towards the ball, run through and take the ball, land on outside foot.

🔄 Change It

Down: Reduce group size (two defenders and two throwers).

Up: Add an extra ball.

❓ Questions

What did you look for when attempting an intercept?

How did you work together as a team (defenders)?

4 on 4 Keeping Off

Objective

To develop intercepting technique.

Equipment/Area

Netball court or suitable playing area.

Size 4 netballs (or equivalent).

Bibs.

Group Management

As a group.

Description

Form two teams of four players.

Team one starts with a ball on a line and passes until it gets to the other line (one point).

Team two defends at 1.2m (4ft) and attempts intercept.

NetSetGO rules apply. If there is a turnover, take it from the nearest end and start again.



! Safety

Define the area appropriate for numbers.

Reinforce the importance of looking out for other players also moving within the area.

🎯 Coaching Tips

Arms over pass:

- Eyes forward
- Bend at knees as required
- Use small steps to move backward to 1.2m, keeping arms by sides
- Extend arms to defend ball.

Intercept:

- Watch thrower to see where they are going to throw the ball (look for cues)
- Run at an angle towards the ball, run through and take the ball, land on outside foot.

↔ Change It

Down: Reduce activity space.

Up: Make playing area bigger; Add competition.

? Question

How did you work together as a team to get an intercept?

NetSetGO Game

Objective

To practise netball skills in a modified NetSetGO match.

Equipment/Area

Netball court or suitable playing area.

Modified goalposts.

Size 4 netball (or equivalent).

Bibs.

Group Management

Two even teams.

Description

Play a modified game.

Introduce wing defence (WD) position.

- What is their role?
- What area do they play in?

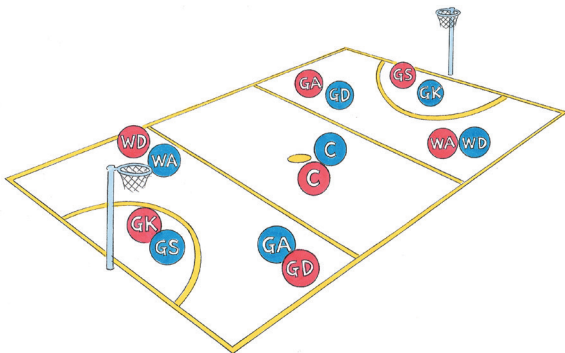

! Safety

Define the area appropriate for numbers.

Reinforce the importance of looking out for other players also moving within the area.

🎯 Coaching Tips

Reinforce footwork rule.

Encourage correct passing and catching technique.

Reinforce use of attacking moves to create space.

Encourage players to shadow opponent and attempt to intercept.

📖 Coach Tip

Know the rules.

Concluding Activity

Objective

To reinforce skills and positions learnt.

Description

Summarise skills covered.

Stretch!

Select an appropriate activity from the Stretch Coaching resource.

Set Session Plans

SESSION

8

Tail Tag

Objective

To practise running and change of direction in a dynamic activity.

Equipment/Area

Netball court or suitable playing area.
Bibs.

Group Management

As a group.

Description

All players tuck a bib or band into the back of their shorts/skirt.

Players must keep moving and grab as many tails as possible while protecting their own tail.

Players cannot hold onto their own tail.

The winner is the one with the most tails after all have been stolen.

There is no elimination.

! Safety

Define the area appropriate for numbers, ensuring there is sufficient space between each group.

Reinforce the importance of looking out for other players also moving within the area.

🎯 Coaching Tips

Eyes looking forward.

Push off the ground with the ball of the foot.

Back leg extends to push off and give more momentum.

Legs and feet move in a straight line.

Arms bent at right angles at the elbows.

Arms and legs move in opposition.

Body leans forward.

↔ Change It

Down: Work in pairs so you can only steal your partner's tail.

Up: Divide the group into teams. Players can only steal the tails of the opposition players, team with the most tails wins.

? Questions

How did you get away and avoid your tail being stolen?

What tactics did you use to steal players' tails?

🏃 Stretch!

Select an appropriate activity from the Stretch Coaching resource.

Shrink and Grow

Objective

To practise catching and throwing techniques.

Equipment/Area

Netball court or suitable playing area.

Size 4 netballs (or equivalent).

Group Management

Pairs.

Description

In pairs, players pass back and forth to each other.

If the ball is dropped, both players kneel on one knee.

Subsequent dropped passes result in the players 'shrinking' to both knees/kneeling, and then finally sitting.

After two consecutive successful passes, players grow again to standing, then progress to step back options (as per L-o-n-g throw).

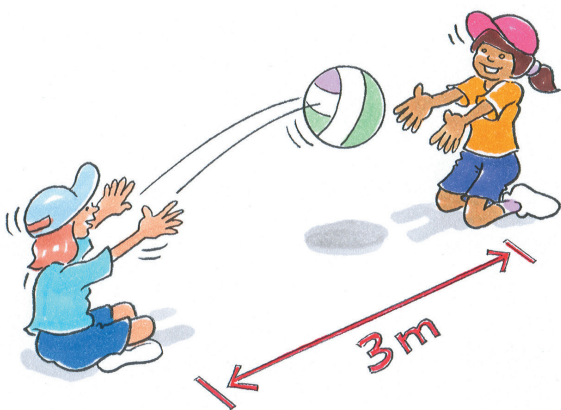

⚠ Safety

Define the area appropriate for numbers.

👁 Coaching Tips

Gain power and distance by stepping forward with opposite foot to throwing hand, rotating the hips and transferring weight from back to front foot.

Non-preferred hand: Encourage players to also practise throwing activities with their non-preferred hand whenever possible.

Distance: Practise throwing for distance (sideline to sideline using a bean bag or knotted bib) as well as shorter distance throwing for accuracy.

↔ Change It

Down: Use bean bags, tennis balls, knotted bibs.

Up: Use different types of passes; Add a defender.

❓ Questions

What different passes did you use?

How were you able to throw further?

Lines

Objective

To practise lead, pivot and passing technique.

Equipment/Area

Netball court or suitable playing area.

Size 4 netballs (or equivalent).

Group Management

As a group.

Description

Players line up one behind the other, facing the thrower.

Player 1 leads out for 2–3 steps at a 45-degree angle forward to thrower.

Player 1 takes the ball out in front, lands on the outside foot and pivots out.

Player 1 then passes to the next lead.

Timing – wait until player before pivots, before next player leads.

Work both sides.

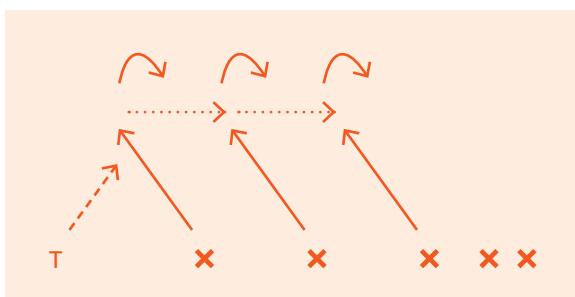

Thrower T Player X

! Safety

Define the area appropriate for numbers.

🎯 Coaching Tips

Ball placement should be out in front of player.

The lead should be angled forward towards the passer.

Lead:

- Run strongly to the ball, shoulders in direction of lead
- If leading right, land on the right foot
- If leading left, land on left foot.

Pivot:

- Pivot must always be on landed foot
- Turn on the ball of the landed foot, pushing off with other foot
- Pivot in the direction of the landed foot.

Pass:

- Eyes on target.
- Step towards target (this should be opposite foot to throwing arm for shoulder pass).
- Transfer weight forward.
- Hip to shoulder rotation during throw.
- Throwing arm follows through to target

Catch:

- Eyes on the ball
- Hands towards the ball
- Fingers forward and spread and thumbs behind the ball ('W' formation)
- Pull ball towards the body.

↻ Change It

Down: Reduce to a group of three; Stationary thrower and receiver.

Up: Add in a dodge.

? Question

Why do you pivot on the outside foot?

Lead and Pivot

Objective

To practise lead, pivot and passing techniques.

Equipment/Area

Netball court or suitable playing area.

Size 4 netball (or equivalent).

Group Management

Groups of four.

Description

Player 1 (X1) leads on a 45-degree angle for 2–3 steps (left or right).

X1 turns their shoulders in direction of lead, catches a pass from the thrower (T) and lands on their outside foot.

X1 then pivots outside and passes to the next player in line (X2), who passes back to the thrower.

The lead should be angled forward towards the passer.

Players should work both sides.

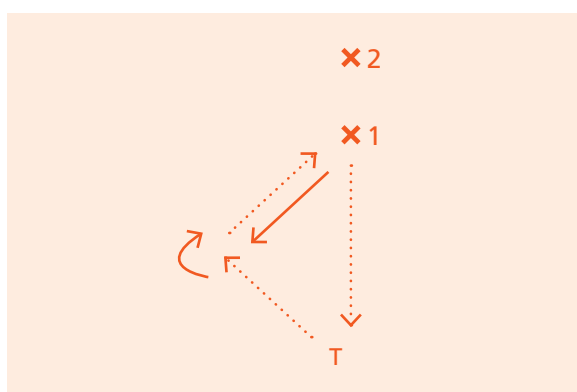

Thrower T Player X

⚠ Safety

Define the area appropriate for numbers.

🎯 Coaching Tips

Ball placement should be out in front of player.

Lead:

- Run strongly to the ball, shoulders in direction of lead
- If leading right, land on the right foot
- If leading left, land on left foot.

Pivot:

- Pivot must always be on landed foot
- Turn on the ball of the landed foot, pushing off with other foot
- Pivot in the direction of the landed foot.

↻ Change It

Down: Remove pass – lead out, land, pivot.

Up: Add defender.

❓ Question

Why is it important to lead at a 45-degree angle?

Straight Lead

Objective

To practise straight lead and passing on the move.

Equipment/Area

Netball court or suitable playing area.

Size 4 netballs (or equivalent).

Group Management

Groups of four.

Description

Player 1 (X1) sprints straight forward to receive a pass from the thrower (T).

X1 lands, steps forward and passes to the receiver (R).

The receiver passes back to the thrower and X1 returns to the end of the line.

Players should use shoulder passes.

Players change sides and swap roles throughout the activity.

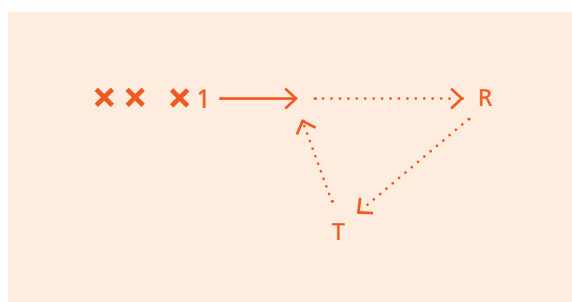

⚠ Safety

Define the area appropriate for numbers.

🕒 Coaching Tips

Ball placement should be out in front of player.

Take off:

- Eyes looking forward
- Push off the ground with the ball of the foot
- Back leg extends to push off and give more momentum
- Legs and feet move in a straight line
- Arms bent at right angles at the elbows
- Arms and legs move in opposition
- Body leans forward
- Knee lifts.

Lead:

- Run strongly to the ball, shoulders in direction of lead
- If leading right, land on the right foot
- If leading left, land on left foot.

Pass:

- Eyes on target
- Step towards target (this should be opposite foot to throwing arm for shoulder pass)
- Transfer weight forward
- Hip to shoulder rotation during throw
- Throwing arm follows through to target.
- Reinforce weight transfer on shoulder pass and catching technique.

Catch:

- Eyes on the ball
- Hands towards the ball
- Fingers forward and spread and thumbs behind the ball ('W' formation)
- Pull ball towards the body.

↔ Change It

Down: Move the thrower to where the receiver stands and remove the receiver.

Up: Add a defender; Change type of pass.

❓ Question

Where would you use a straight lead in a netball game?

NetSetGO Game

Objective

To practise netball skills in a modified NetSetGO match.

Equipment/Area

Netball court or suitable playing area.

Modified goalposts.

Size 4 netball (or equivalent).

Bibs.

Group Management

Two even teams.

Description

Play a modified game.

Introduce basic centre pass attack strategies.

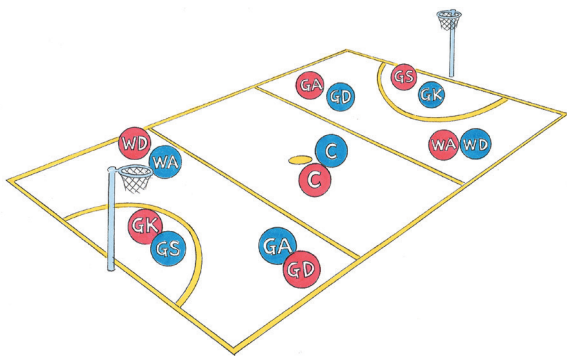

! Safety

Define the area appropriate for numbers.

Reinforce the importance of looking out for other players also moving within the area.

🎯 Coaching Tips

Reinforce footwork rule.

Encourage correct passing and catching technique.

Reinforce use of attacking moves to create space.

Encourage players to shadow opponent and attempt to intercept.

👉 Coach Tip

Encourage teamwork.

Concluding Activity

Objective

To reinforce skills and positions learnt.

Description

Summarise skills covered.

Stretch!

Select an appropriate activity from the Stretch Coaching resource.

Set Session Plans

SESSION

9

Flip it

Objective

To practise running and change of direction in a dynamic activity.

Equipment/Area

Netball court or suitable playing area.

Markers or coloured paper (different colour each side).

Group Management

Two teams.

Description

Split the group into two teams.

Each player has a marker. One team places them correctly on the ground and the other team places them on the ground upside down.

On a command, players run around to try and turn the other team's markers over to match their own.

After a set period of time, the team with the most markers the same wins.

⚠ Safety

Define the area appropriate for numbers, ensuring there is sufficient space between each group.

Reinforce the importance of looking out for other players also moving within the area.

👁 Coaching Tips

Eyes looking forward.

Push off the ground with the front part of the foot.

Extend back leg.

Knees bent at right angles when moving forward.

Legs and feet move in a straight line.

Arms bent at right angles at the elbows.

Arms and legs move in opposition.

Contact ground with front part of foot.

Body leans forward.

↻ Change It

Down: All players are on the same team. Players stand outside the area, and on a command they run in and flip all the markers over.

Up: Player must run to a corner after each flip.

🏃 Stretch!

Select an appropriate activity from the Stretch Coaching resource.

Train Tag

Objective

To practise change of direction using quick footwork.

Equipment/Area

Netball court or suitable playing area.

Group Management

Groups of four.

Description

Three players stand in single file (train) holding the waist of the person in front, with another player standing facing the line (the tagger).

The tagger aims to tag the player at the back of the train.

Players keep the train intact and aim to reposition to protect the back carriage of the train from being caught by the tagger.

After a designated time frame or after tagging the back carriage, players change roles.

⚠ Safety

Define the area appropriate for numbers, ensuring there is sufficient space between each group.

Reinforce the importance of looking out for other players also moving within the area.

👁 Coaching Tips

Eyes looking forward.

Move feet using small steps.

Feet shoulder-width apart.

Change direction by pushing off on outside foot.

↻ Change It

Down: The two back players in the line can be tagged.

Up: Introduce a time limit.

❓ Question

How might you use quick footwork like this in a netball match?

One-on-One Defence

Objective

To develop defensive and footwork skills.

Equipment/Area

Netball court or suitable playing area.

Size 4 netballs (or equivalent).

Group Management

Groups of three.

Description

Players form groups of three – one attacker (A), one defender (D) and one thrower (T).

The attacker moves side to side and the defender shadows while watching the ball.

After the defender is comfortable, the thrower passes to the attacker while the defender attempts to intercept.

Players rotate and experience all positions.

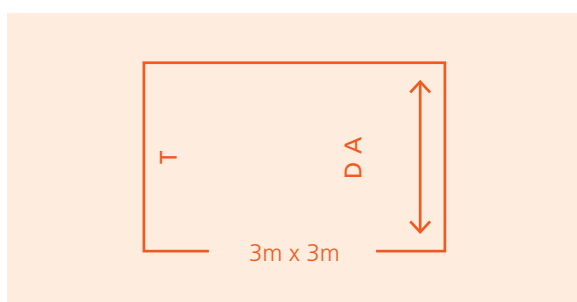

! Safety

Define the area appropriate for numbers, ensuring there is sufficient space between each group.

🎯 Coaching Tips

Small quick steps.

Eyes focus ahead rather than back on opponent.

Shadow:

- Start standing in front of opponent with back to attacker, half way across attacker's body
- Arms close to sides of body, feet shoulder-width apart, knees slightly bent
- Vision to see both attacker and ball
- Use small, fast steps to maintain position
- Don't move head.

Intercept:

- Watch thrower to see where they are going to throw the ball (look for cues)
- Run at an angle towards the ball, run through and take the ball, land on outside foot.
- Drive forward towards the ball when taking intercept.

↻ Change It

Down: Limit attacking moves to side to side.

Up: Variety of passes; Increase space.

? Question

What did you look for when attempting an intercept?

Pig in the Middle (Variation)

Objectives

To practise passing technique in a dynamic activity.

To develop intercept technique.

Equipment/Area

Netball court or suitable playing area.

Size 4 netballs (or equivalent).

Group Management

Groups of four.

Description

Divide the group into one defender (D), one thrower (T), and two passers (P1 and P2).

Players stand in a circle with the defender inside the circle.

The thrower passes to (P1) or (P2). The defender attempts to intercept.

Player first steps forward, then leads out at 45 degrees.

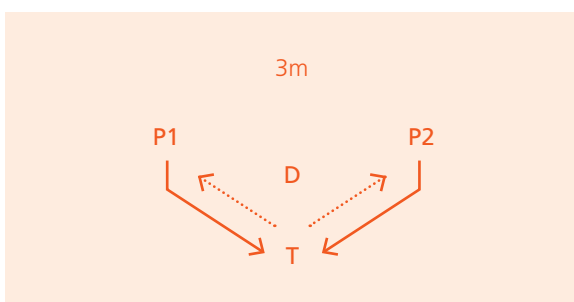

⚠ Safety

Define the area appropriate for numbers, ensuring there is sufficient space between each group.

🎯 Coaching Tips

Pass:

- Eyes on target
- Step towards target (this should be opposite foot to throwing arm for shoulder pass)
- Transfer weight forward
- Hip to shoulder rotation during throw
- Throwing arm follows through to target.
- Two hands on the ball.
- No fakes from the thrower.

Intercept:

- Watch thrower to see where they are going to throw the ball (look for cues)
- Run at an angle towards the ball, run through and take the ball, land on outside foot.
- Chase tips.

🔄 Change It

Down: Use a soft ball.

Up: Have two defenders in the middle.

❓ Question

What did you look for when trying to get an intercept?

In the Middle

Objective

To practise intercept technique.

Equipment/Area

Netball court or suitable playing area.

Size 4 netballs (or equivalent).

Group Management

Groups of four.

Description

Players form a square with a defender (D) inside.

The ball is passed around the square and the defender attempts to intercept.

Score one point for a tip and two points for an intercept.

After four points, another player becomes the defender.

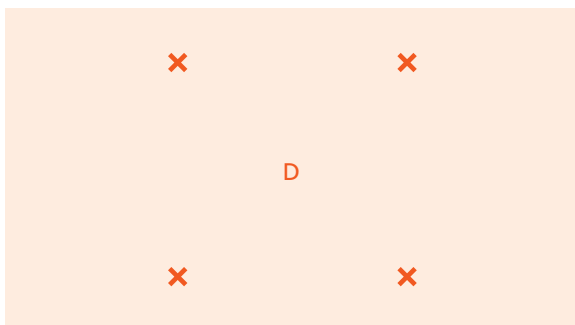

! Safety

Define the area appropriate for the numbers and selected activity.

🎯 Coaching Tips

Pass:

- Eyes on target
- Step towards target (this should be opposite foot to throwing arm for shoulder pass)
- Transfer weight forward
- Hip to shoulder rotation during throw
- Throwing arm follows through to target.

Intercept:

- Watch thrower to see where they are going to throw the ball (look for cues)
- Run at an angle towards the ball, run through and take the ball, land on outside foot.

↻ Change It

Down: Decrease size of the square.

Up: Increase size of the square.

? Question

What did you look for when trying to get an intercept?

NetSetGO Game

Objective

To practise netball skills in a modified NetSetGO match.

Equipment/Area

Netball court or suitable playing area.

Modified goalposts.

Size 4 netball (or equivalent).

Bibs.

Group Management

Two even teams.

Description

Play a modified game.

Introduce basic centre pass attack strategies.

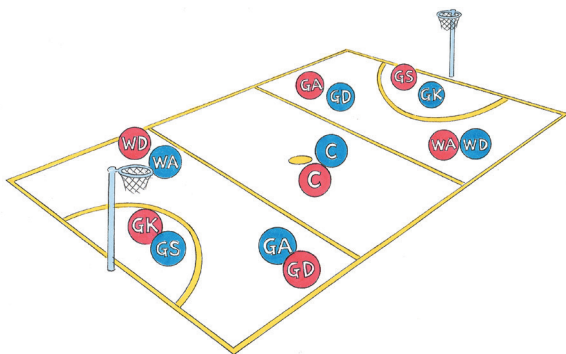

! Safety

Define the area appropriate for numbers.

Reinforce the importance of looking out for other players also moving within the area.

🎯 Coaching Tips

Reinforce footwork rule.

Encourage correct passing and catching technique.

Reinforce use of attacking moves to create space.

Encourage players to shadow opponent and attempt to intercept.

📌 Coach Tip

Provide challenges with the opportunity for success.

Concluding Activity

Objective

To reinforce skills and positions learnt.

Description

Summarise skills covered.

Stretch!

Select an appropriate activity from the Stretch Coaching resource.

Set Session Plans

SESSION

10

Tunnel Ball

Objective

To develop hand–eye coordination and practise rolling the ball in a confined space.

Equipment/Area

Netball court or suitable playing area.

Size 4 netballs (or equivalent).

Group Management

Groups of 4–5.

Description

Players line up in teams of four, one behind the other.

The ball is passed to the end of the line between the legs of all team members.

The last person then runs to the front of the line and starts passing the ball again.

The winning group is the first back to their original position.

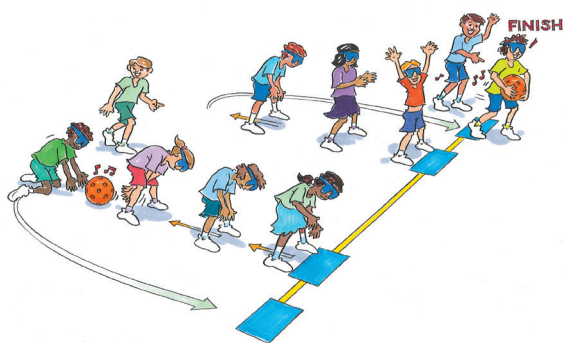

! Safety

Define the area appropriate for numbers, ensuring there is sufficient space between each group.

🎯 Coaching Tips

Eyes on the ball.

Hands towards the ball.

Fingers forward and spread and thumbs behind the ball ('W' formation).

Pull ball towards the body.

↻ Change It

Down: No competition; Use a beanbag.

Up: Pass the ball over the heads of the players; Pass the ball in an over and under pattern; Pass the ball twisting to the left and right; Combine the different variations in one race.

🏃 Stretch!

Select an appropriate activity from the Stretch Coaching resource.

Modified Around the World

Objective

To practise lead, passing and catching techniques in a dynamic activity.

Equipment/Area

Netball court or suitable playing area.

Size 4 netballs (or equivalent).

Group Management

Groups of 5–6.

Description

Players are put into two even teams, one team forming an outer circle (X) and the other team inside the circle (O).

The players in the outside circle each have a ball.

Each X passes to an O. O passes back then jogs around the back of the player they received the pass from, and then sprints back into the circle and receives a pass from another X.

Play for three minutes then swap roles. Repeat twice.

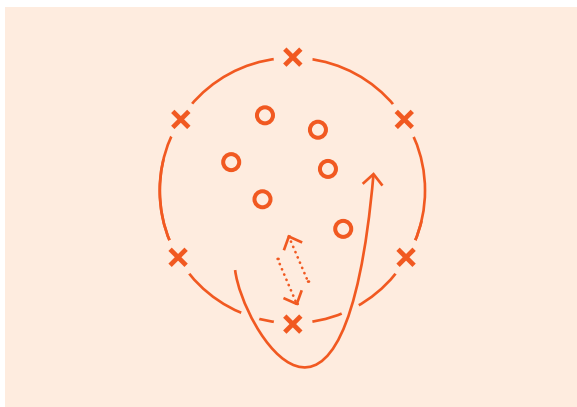

! Safety

Define the area appropriate for numbers, ensuring there is sufficient space between each group.

Reinforce the importance of looking out for other players also moving within the area.

🕒 Coaching Tips

Reinforce passing and catching technique.

Use a variety of attacking moves to create space and receive pass.

🔄 Change It

Down: Use a soft ball; Only one (O) in the middle; Only one (X) has a ball and (O) passes back to another (X).

Up: Play as a larger group; Introduce a competition.

? Question

What kind of movements did you use to create space?

Passing Variety

Objective

To practise change of direction and dodge techniques incorporating a ball.

Equipment/Area

Netball court or suitable playing area.

Size 4 netball (or equivalent).

Group Management

Pairs.

Description

(F) is 7.5m away from the line and (W) half-way facing (F).

(W) turns, runs to the line, changes direction, drives back and receives a pass (10 times).

Use a variety of passes – lob, bounce, chest and shoulder.

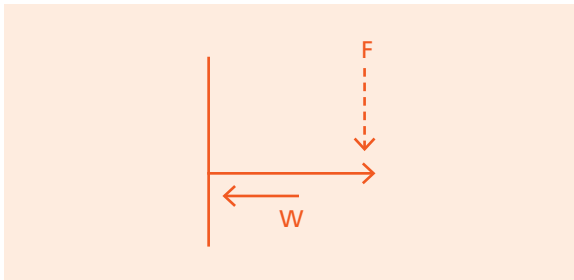

! Safety

Define the area appropriate for numbers.

🎯 Coaching Tips

Pass:

- Reinforce coaching points for all passes
- Ball placement should be out in front of player.

Dodge:

- Place outside foot strongly on ground and push off in opposite direction, turning hips to face towards direction of travel.

🔄 Change It

Down: Set up markers for players to move between.

Up: Add a defender; Increase distance to extend pass.

? Question

Where could you use this skill in a netball match?

Lob

Objective

To develop lob passing technique.

Equipment/Area

Netball court or suitable playing area.

Size 4 netball (or equivalent).

Group Management

Pairs.

Description

Pairs:

- One ball between two, passing to each other
- Pass five lob passes each side then swap roles.

Extension:

- (A) and (B) stand next to each other
- (A) passes a lob out in front and (B) drives forward to receive a high pass and lands on their outside foot. (B) pivots and passes back to (A).

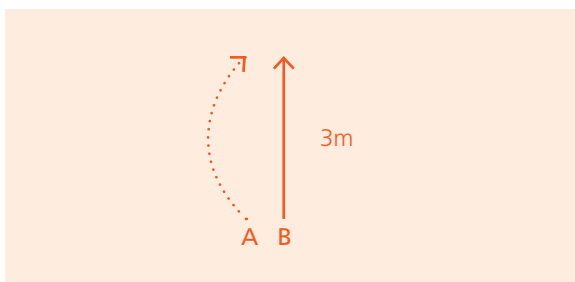

⚠ Safety

Define the area appropriate for numbers, ensuring there is sufficient space between each group.

🎯 Coaching Tips

Passing movement starts from shoulder.

Short back movement.

One-handed high release.

Follow through in direction of pass with wrist/fingers.

Thrower passes into space.

🔄 Change It

Down: Lob to stationary player.

Up: Add defender.

❓ Question

What did you do to make sure the pass was lifted over the defender?

Square Drill – Shoulder Pass

Objective

To practise straight leads and shoulder pass techniques in a dynamic activity.

Equipment/Area

Netball court or suitable playing area.

Size 4 netballs (or equivalent).

Group Management

As a group.

Description

Form a square with 2-3 players in each corner.

Start the ball with (X1) who is halfway between two corners.

X1 passes the ball to the first player at the next corner who drives straight out to take the ball at extension.

Continue around the square.

Players run to the back of the line they have just thrown to.

Run the activity both clockwise and anticlockwise.

⚠ Safety

Define the area appropriate for the numbers and selected activity.

🎯 Coaching Tips

Reinforce shoulder pass and catching technique.

Ball placement ahead of leading player.

Sprint strongly to the ball.

Maintain speed onto the ball.

🔄 Change It

Down: Make the size of the square smaller.

Up: Increase the size of the square.

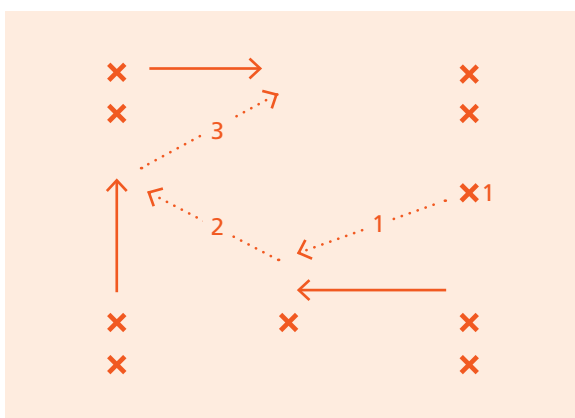

NetSetGO Game

Objective

To practise netball skills in a modified NetSetGO match.

Equipment/Area

Netball court or suitable playing area.

Modified goalposts.

Size 4 netball (or equivalent).

Bibs.

Group Management

Two even teams.

Description

Play a modified game.

Introduce basic throw-in strategies.

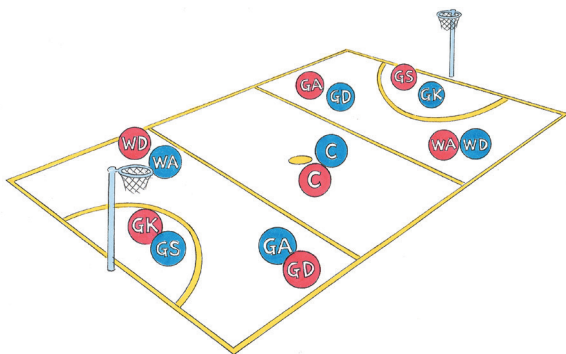

! Safety

Define the area appropriate for numbers.

Reinforce the importance of looking out for other players also moving within the area.

🎯 Coaching Tips

Reinforce footwork rule.

Encourage correct passing and catching technique.

Reinforce use of attacking moves to create space.

Encourage players to shadow opponent and attempt to intercept.

👉 Coach Tip

Players like to play the game.

Concluding Activity

Objective

To reinforce skills and positions learnt.

Description

Summarise skills covered.

Stretch!

Select an appropriate activity from the Stretch Coaching resource.

Coaching Points

Footwork, Balance and Movement Skills

Initial Stance

Forms the starting point for most attacking and defending skills.

Teaching Points	Common Errors
<ul style="list-style-type: none"> ✓ Feet shoulder-width apart ✓ Shoulders back and down ✓ Knees slightly flexed ✓ Knees over toes ✓ Head up with eyes looking in direction of play ✓ Arms relaxed by side of body ✓ Centre of gravity is low and over base of support 	<ul style="list-style-type: none"> ✗ Base of support too narrow ✗ Shoulders forward and leaning inward ✗ Knees straight ✗ Knees not over toes ✗ Head down ✗ Arms tensed and away from body ✗ Centre of gravity high and not over base of support

Safe Landing

When landing on one leg it is important to teach the players which foot they should be landing on.

Teaching Points	Common Errors
<p>Two Feet</p> <ul style="list-style-type: none"> ✓ Land with feet shoulder-width apart to give a firm support base ✓ Keep body upright, bend at hips, knees and ankles on impact to cushion landing ✓ Continue to bend knees after impact to assist with a balanced soft landing ✓ Body weight over both feet with shoulders even and weight on both feet <p>Right / Left Foot</p> <ul style="list-style-type: none"> ✓ If player leads to the left, they should land on the left (outside) foot. If they lead to the right, land on the right foot ✓ Body weight over the outside foot with shoulders even and weight on the outside foot ✓ Place other foot on the ground quickly to help absorb impact and provide balance 	<p>Two Feet</p> <ul style="list-style-type: none"> ✗ Landing with feet too close together ✗ Not continuing to bend knees, ankles and hips on and after impact <p>Right / Left Foot</p> <ul style="list-style-type: none"> ✗ Landing on incorrect foot (inside) ✗ Not bending knees, ankles and hips on and after impact and weight on the outside foot to cushion landing ✗ Second foot not landing quickly and overbalancing on first ✗ One shoulder is dipped – usually same side as landed foot

Take-Off

Stride length should be short on take-off.

Teaching Points	Common Errors
<ul style="list-style-type: none">✓ Arms/legs move in opposition✓ Lean body forward✓ Start with small steps and gradually move to bigger steps✓ Arms drive forward in relaxed style, elbows bent✓ Keep head erect and eyes up✓ If leading to the right, take off with the right foot and vice versa	<ul style="list-style-type: none">✗ Initial step back before driving forward✗ Same arm and same leg✗ Arms at side of body not driving or swinging across the body✗ Stride length too big✗ Eyes looking down

Jumping and Leaping

Whether the take off for a high ball is made from one foot or two will largely depend on where the ball is placed.

Teaching Points	Common Errors
<p>Two Foot Jump</p> <ul style="list-style-type: none"> ✓ Bend slightly at the knees, hips and ankle, weight forward over toes ✓ Step into take off with a quick left/right or right/left step pattern ✓ Use both arms to drive up to extend towards the ball ✓ Land on both feet, cushioning landing by bending at knees, hips and ankles <p>One Foot Leap – Right / Left Foot</p> <ul style="list-style-type: none"> ✓ Bend slightly at the knees, hips and ankle, weight forward over toes ✓ Push strongly off take-off foot ✓ Drive arms up to extend towards ball ✓ Land on the foot away from the thrower, cushioning the land by bending at knees, hips and ankles <p>Hopping</p> <ul style="list-style-type: none"> ✓ Bend slightly at the knees, hips and ankle, weight forward over toes ✓ Step into take off with a quick left/right or right/left step pattern ✓ Use both arms to drive up to extend towards the ball ✓ Land on both feet, cushioning landing by bending at knees, hips and ankles <p>Skipping</p> <ul style="list-style-type: none"> ✓ Bend slightly at the knees, hips and ankle, weight forward over toes ✓ Step into take off with a quick left/right or right/left step pattern 	<p>Two Foot Jump</p> <ul style="list-style-type: none"> ✗ Weight back on heels of feet before take off ✗ Extra step not taken so only a one-foot take off used ✗ Knee straight before take off ✗ Arms not used to extend to full height ✗ Landing on one foot ✗ Timing of jump is incorrect <p>One Foot Leap – Right / Left Foot</p> <ul style="list-style-type: none"> ✗ Weight back on heels of feet before take off ✗ Knee straight before take off ✗ Arms not used to extend to full height ✗ Landing on incorrect foot (inside foot) ✗ Timing of jump is incorrect <p>Hopping</p> <ul style="list-style-type: none"> ✗ Weight back on heels of feet before take off ✗ Knee straight before take off ✗ Arms not used to extend to full height ✗ Landing on incorrect foot (inside foot) ✗ Timing of jump is incorrect <p>Skipping</p> <ul style="list-style-type: none"> ✗ Weight back on heels of feet before take-off ✗ Knee straight before take-off ✗ Pattern of skipping is incorrect

Pivot

An outside pivot continues the natural body movement after a player receives a ball at full stretch.

Teaching Points	Common Errors
<p>Pivoting must always be on the landing foot</p> <ul style="list-style-type: none">✓ Bring weight over grounded foot✓ Bend knees slightly✓ Turn on ball of the pivot foot, pushing off with the other foot✓ Non-grounded foot is lifted and regrounded to maintain balance throughout movement✓ Players must be able to turn quickly after receiving a pass and face the play down court✓ Keep ball close to body and positioned ready to throw <p>Remember:</p> <ul style="list-style-type: none">✓ When leading to right, land on right foot and pivot to right✓ When leading to left, land on left foot and pivot to left✓ When leading straight, pivot on first landed foot away from defended side	<ul style="list-style-type: none">✗ Landing on incorrect foot✗ Pivoting before the ball is securely caught✗ Pivoting into opponent✗ Dragging the pivoting foot on the pivot action✗ Pivoting with the leg straight✗ Weight not over grounded foot✗ Grounded foot is lifted and regrounded during pivot✗ Weight of grounded foot is moved from heel to toe during pivot✗ Ball not brought into body after catch

Ball Skills

Catch

Encourage players to catch with two hands to increase control.

Teaching Points	Common Errors
<p>Two-Hand Catch</p> <ul style="list-style-type: none"> ✓ Eyes on the ball ✓ Move towards the ball ✓ Extend hands forward with fingers spread and thumbs behind the ball ('W' formation) ✓ Extend arms to meet and snatch ball towards the body and control it with fingers and thumbs 	<p>Two-Hand Catch</p> <ul style="list-style-type: none"> ✗ Eyes not on the ball ✗ Catching with the palms of the hand ✗ Thumbs not behind ball ✗ Arms bent and close to body ✗ Not taking the ball while on the move ✗ Movement away from the ball

Shoulder Pass

One-hand pass used for speed and accuracy over long distances.

Teaching Points	Common Errors
<ul style="list-style-type: none"> ✓ Opposite foot to the throwing arm forward ✓ Feet shoulder-width apart, with weight on back foot at start of throw ✓ Ball held with two hands initially then in one hand with arm back behind the shoulder ✓ Arms extended with elbow slightly bent, shoulders turned ✓ Fingers spread wide behind the ball ✓ Transfer weight forward as throwing arm comes through ✓ Follow through throwing arm until almost extended, fingers and wrist extend in the direction of the pass ✓ Rotate hips and shoulders towards target ✓ Direct pass to space ahead of receiver 	<ul style="list-style-type: none"> ✗ Same foot as arm forward ✗ Throwing hand resting on shoulder ✗ Weight on front foot initially – little with transfer resulting in loss of power ✗ No transfer of weight from back foot to front foot ✗ Ball held in palm ✗ Elbow not bent when taken back ✗ No shoulder rotation as ball taken back – stab pass ✗ No hip/shoulder rotation as ball comes through ✗ Arm taken back too high and the ball travels down on release ✗ Hand under ball causing spin on release ✗ Pass not directed to space in front of receiver

Chest Pass

Pass with two hands from the chest (used for quick, short and accurate passes).

Teaching Points	Common Errors
<ul style="list-style-type: none">✓ Stand front on with the ball in two hands at chest height and elbows down✓ Spread fingers around the ball with thumbs behind✓ Step forward with weight transferred onto front foot as you push the ball with wrist and fingers✓ Ball comes out evenly from both hands✓ Head up, eyes looking forward	<ul style="list-style-type: none">✗ Elbows at shoulder height✗ Hands at the side of the ball with thumbs upward✗ No weight transfer, use upper body only✗ Ball pushed from palm – lack of touch on pass✗ One hand dominates pass✗ Head down looking at ball

Bounce Pass

Used when the thrower is closely defended or when play is crowded, generally over short distances.

Teaching Points	Common Errors
<ul style="list-style-type: none">✓ Step forward and bend/lunge on opposite leg✓ Push ball forward and downward✓ Release ball between the hip and knee✓ The path of the ball is lower – under the outstretched hands of the defender✓ The ball should touch the ground approximately two thirds of the distance to the receiver and reach the intended player about knee height	<ul style="list-style-type: none">✗ Step is across body✗ Pass not directed downward✗ Ball released at shoulder height✗ No weight transfer✗ Bounce the ball too close to the thrower✗ Bounce the ball too high

Ball Skills (cont.)

Lob

A high pass used to lift the ball over the arms of the defending players.

Teaching Points	Common Errors
<ul style="list-style-type: none"> ✓ Start movement from the shoulder ✓ Short back movement ✓ One-handed high release ✓ Follow through in direction of pass with wrist/fingers 	<ul style="list-style-type: none"> ✗ Ball begins at waist/hip level ✗ Large 'back swing' movement ✗ Ball released from chest position ✗ No follow through, arm action 'stabs' pass

Ball Placement

An important aspect of all passes.

Teaching Points	Common Errors
<ul style="list-style-type: none"> ✓ Place in front of moving player ✓ Receiver to receive at full stretch, in front of defender ✓ Into space created by attacker – hold for a bounce or a lob 	<ul style="list-style-type: none"> ✗ Pass placed behind or at receiver ✗ Pass too high or low ✗ Receiver moves off too soon – allowing defender to move into the space created

Shooting Skills

Shooting

Predominantly a one-handed shot with the other hand resting on the side of the ball.

Teaching Points	Common Errors
<ul style="list-style-type: none">✓ Ball is held above the head✓ Arms are extended with the shooting arm reasonably straight and close to the ear✓ Ball rests on the base of the spread fingers and the thumb✓ The opposite hand is placed on the side of the ball to steady it✓ Stand upright with the feet about shoulder-width apart✓ Feet, hips and elbows pointing towards the goalpost✓ Bend elbows and knees✓ Straighten elbows and knees✓ Release the ball just before elbows and knees are straight✓ Flick the ball with the wrist✓ Follow through, arms towards post✓ Straighten fingers pointing them towards the post✓ The ball should travel in an arc towards the post	<ul style="list-style-type: none">✗ Ball is behind or in front of head✗ Arm is extended out from ear✗ Fingers not spread wide and the ball sits either flat on the palm or up on the fingertips✗ Opposite hand is placed under the ball✗ Feet too close or too far apart and body is hunched✗ Feet, hips and elbows not aligned with each other and the post✗ Keeping elbows and knees extended and ball dropping behind the head✗ Keeping elbows and knees flexed on the release phase of the shot✗ Releasing ball after elbows and knees are straight✗ Not using any wrist action✗ Arms not following the ball in the direction of release✗ Fingers not pointing in the direction of the ball release✗ The ball travels flat in the air

Attacking Skills

Timing of Lead

An important aspect of all attacking moves.

Teaching Points	Common Errors
<ul style="list-style-type: none"> ✓ Reading cues from the thrower ✓ Reading available space 	<ul style="list-style-type: none"> ✗ Moving too early before thrower is ready to release ✗ Driving into space already taken

Straight Lead

Timing is key for successful execution.

Teaching Points	Common Errors
<ul style="list-style-type: none"> ✓ Sprint strongly to the ball, either directly forward or diagonally at a 45-degree angle to the free side ✓ When the lead is to the right, take off with the right leg and vice versa ✓ Emphasis should be on strong first 3–4 steps with shoulders in direction of lead ✓ When leading to the right, land on the right foot and pivot to the right ✓ When leading to the left, land on the left foot and pivot to the left ✓ Strong arms to accelerate ✓ Maintain speed onto ball 	<ul style="list-style-type: none"> ✗ Leading too soon ✗ Step back before drive forward or taking off with the incorrect leg ✗ Run with body 'flat' to ball ✗ Arms swing across body or not at all ✗ Lead is to the side but not towards the ball ✗ Slow down before the pass is taken ✗ Landing on the inside leg

Single Dodge

Movements should be quick and decisive.

Teaching Points	Common Errors
<ul style="list-style-type: none">✓ Eyes on thrower✓ Body upright, feet shoulder-width apart, slightly bent knees and hips✓ Move a few steps away from the intended catching position (should be a definite move)✓ Place outside foot strongly on ground and push off in the opposite direction, turning hips to face towards direction of travel✓ Use arms to accelerate and extend to receive ball	<ul style="list-style-type: none">✗ Feet too far apart✗ No weight transfer onto outside foot✗ Push off on the inside foot✗ Dodge not a definite movement, just a sway✗ Movement too slow, allowing defender to hold attacker's position✗ Moving head and losing sight of thrower✗ Eyes and head looking down✗ Arms beside body and not using to increase power

Change of Direction (Two Straight Leads)

First movement is longer than that used in a single dodge.

Teaching Points	Common Errors
<ul style="list-style-type: none">✓ Sprint strongly to the ball, either directly forward or diagonally at a 45-degree angle. Shoulders should be in direction of movement✓ Emphasis should be on strong first 3–4 steps✓ Push off strongly on outside foot and use inside foot as take-off foot to move into a new space✓ Emphasis again on strong first steps when moving to the new space	<ul style="list-style-type: none">✗ Leading too soon✗ Shoulders not turned in direction of lead✗ Push off on the inside foot✗ Movement onto second move not definite✗ Not changing direction into a free space✗ Arms beside body and not using to increase power✗ Eyes and head looking down

Defence Skills

One on One Shadowing

Basic defending position.

Teaching Points	Common Errors
<ul style="list-style-type: none"> ✓ Stand in front of opponent with back to attacker and body halfway across opponent's body ✓ Arms close to sides of body ✓ Feet shoulder-width apart, knees bent, weight slightly forward over toes and back upright ✓ Vision to see attacker and the ball ✓ Shadow moves using fast small steps ✓ Aim to move feet, keep head up and maintain vision of the attacker and not swing head 	<ul style="list-style-type: none"> ✗ Standing directly in front of attacker or directly beside attacker ✗ Watching either the ball or the attacker exclusively ✗ Bottom is not tucked in and legs straight ✗ Feet too close together or too far apart ✗ Arms positioned out from the body causing obstruction ✗ Moving head and not feet to maintain vision on attacker

Interception

Reading the pattern of play allows the defender to predict the most likely passing option.

Teaching Points	Common Errors
<ul style="list-style-type: none"> ✓ Read cues provided by thrower to anticipate direction of pass ✓ Drive for an intercept at an angle ✓ Focus on ball ✓ Emphasis should be on strong first 3–4 steps ✓ Run through to take the ball ✓ Land on the outside foot and balance 	<ul style="list-style-type: none"> ✗ Misreading the cues ✗ Leading too soon ✗ Angle too flat ✗ Eyes and head looking forward ✗ Push off on the inside foot ✗ Lunging at the ball ✗ Landing on incorrect foot and overbalancing

Recovery to 0.9m (3 feet) for Netball and 1.2m (4 feet) for NetSetGO

Quick recovery enables the defender to position to defend the next pass.

Teaching Points	Common Errors
<ul style="list-style-type: none">✓ Push off strongly 0.9m distance (1.2m for NetSetGO)✓ Strong stride/jump back – can be one large stride or a few quick steps✓ Use arms for power to jump back✓ Head up with eyes on ball and opponent	<ul style="list-style-type: none">✗ Push off not quick enough to get back to distance✗ Feet too wide or too close together – difficult to change direction✗ Eyes on ground – attempting to judge distance

Hands Over Ball (NetSetGO Distance is 1.2m)

Balance should be maintained ready to defend the attacker after they release the ball.

Teaching Points	Common Errors
<ul style="list-style-type: none">✓ Stand 0.9m in front of the person throwing (1.2m for NetSetGO)✓ Feet shoulder-width apart, knees, hips and ankles slightly bent✓ Weight balanced over two feet with knees over toes and entire foot on ground✓ Arms up and in position over the ball	<ul style="list-style-type: none">✗ Incorrect distance✗ Hands coming up before correct distance is taken✗ Feet narrow/legs straight/on toes – lose balance and shorten distance✗ Bend forward too much at waist✗ Arms waving and not defending ball

Disclaimer

The NetSetGO resources have been designed for use with participants aged 5–10 years. Each session assumes that each participant is healthy and has no medical condition, disability, illness, impairment or other reason that may impact, limit or restrict their involvement in sport or other physical activity. A participant should not be allowed to participate in an activity if any medical, physical or other factor indicates that they are not suited to that activity. Where there are any queries or concerns about such matters, the consent of the participant's parent or guardian should be obtained before allowing participation. While care has been taken in the preparation of these sessions, the publisher and authors do not accept any liability arising from the use of the resources, including, without limitation, from any activities described within the sessions.

Copyright

The Netball Australia and NetSetGO logo and other intellectual property contained in this resource are protected by national and international laws and conventions on Trademarks and Copyright.

All reproductions, even partial, and any use of Netball Australia intellectual property is not permitted without prior written approval.

Unless otherwise specified, all images are the property of Netball Australia.

Design

Studio Brave

Images

G.Robey Design

For general enquiries

Phone: +61 3 8621 8600

Email: netsetgo@netball.asn.au

www.netsetgo.asn.au



Netball Australia
191 Johnston Street, Fitzroy VIC 3065
www.netball.com.au